







































































PIUSI

**CATALOGUE
ADBLUE®**

ADBLUE® PRODUCT RANGE

PRODUCT RANGE	PRODUCT CATEGORY	PRODUCT	PAGE	
CAR FILLING 	FILLING SYSTEMS	 DELPHIN PRO_X	8	
		 DELPHIN PRO	10	
		 DELPHIN PRO IBC	12	
		 FLIPPER	14	
		 EDGARD	16	
FUEL MANAGEMENT SYSTEMS 	FUEL MANAGEMENT SYSTEMS	OVERVIEW	22	
		SOFTWARE	 B.SMART	24
		DISPENSER	 ADD-ONS	26
		CONTROL BOX	 SELF SERVICE B.SMART	28
		SOFTWARE	 MCBX B.SMART	30
		DISPENSER	 SSM2.0	32
		CONTROL BOX	 DATA TRANSFER SSM 2.0	34
		DISPENSER	 SELF SERVICE MC 2.0	36
		CONTROL BOX	 MCBX 2.0	38
		SOFTWARE	 SSM AGILIS	40
		DISPENSER	 DATA TRANSFER SSM AGILIS	42
		CONTROL BOX	 CUBE ADBLUE AGILIS	44
			 SELF SERVICE MC	46
		 MCBX	48	
KITS	DRUM	 SUZZARABLUE DRUM	54	
	IBC	 SUZZARABLUE 3 PRO	56	
		 SUZZARABLUE 3 BASIC	58	
		 SUZZARABLUE PORTABLE KIT	60	
	ST	 SUZZARABLUE BOX	62	
PUMPS 	AC PUMP	 SUZZARABLUE PUMP AC	68	
	DC PUMP	 SUZZARABLUE PUMP DC	70	
	SUBMERSIBLE PUMP	 SQUALO35/SUBLOCK	72	
	PNEUMATIC DIAPHRAGM PUMPS	 (EX) PRO ONE 15 - MP	74	
		 (EX) PRO ONE 25 - MP	76	
	HAND PUMPS	 PIUSI HAND PUMP	78	
		 PIUSI HAND PUMP IBC	80	
 SUZZARABLUE HAND PUMP		82		
METERS 	ELECTRONIC METERS	 K24	88	
		 TURBINOX	90	
		 MK325 METER	92	
		 REMOTE DISPLAY	94	
METERED NOZZLES 	AUTOMATIC METERED NOZZLES	 SB325_X METER/ SB325_X METER CAR	100	
NOZZLES 	AUTOMATIC NOZZLES	 SB325_X/ SB325_X CAR	106	
		 SUZZARABLUE A60	108	
	MANUAL NOZZLE	 SUZZARABLUE MANUAL NOZZLE	110	

All Pictures shown are for illustration purpose only. Actual product may vary due to product enhancement.

PRODUCT RANGE	PRODUCT CATEGORY	PRODUCT	PAGE
FILTRATION 	FILTER	 3D FILTER	116
TANK MONITORING 	TANK LEVEL INDICATOR	 OCIO	120
HOSE REEL 	OPEN HOSE REEL	 ADBLUE® HOSE REEL	126
ACCESSORIES 	ACCESSORIES	 CONNECTIONS&CONNECTORS	132
		 COUPLING&FITTINGS	134
		 HOSE&SWIVEL	136
MERCHANDISE 	MERCHANDISE	          	140

PIUSI'S ADBLUE® JOURNEY

THE HISTORY OF KNOW-HOW

ABOUT US

PIUSI was established in 1953 in Suzzara, in the province of Mantua (Italy). For more than 60 years, **PIUSI has been the major player in the world's leading markets with its full range of products for transferring, refilling and measuring lubricants, fuels and liquids such as gasoline, diesel, Diesel Exhaust Fluid (DEF), oil, water and grease.**

Some of PIUSI's main products include pumps, flow meters, nozzles, dispensers, hose reels, liquid level gauges, software and complete kits used by operators in agriculture, the automotive industry, workshops and garages, fleet management and transport by road and by sea. PIUSI products have many different uses such as monitoring and transferring fuel at trucking companies, refueling of agricultural vehicles, transferring fuels in construction and mining for heavy duty vehicles. The products are intuitive and easy to use; are suitable to be installed in a variety of contexts; are all made entirely in Italy; and all products express the innovation, quality, professionalism and R&D that have always distinguished PIUSI. Its headquarters are in Suzzara (Mantova - 150 km from Milan and Venice). The company currently employs more than 250 employees between sales, administration, R&D, production and logistics. PIUSI products are sold in more than 120 countries around the world thanks to a large network of distributors and the US branch based in Fort Lauderdale, FL, serving the North and South American markets.

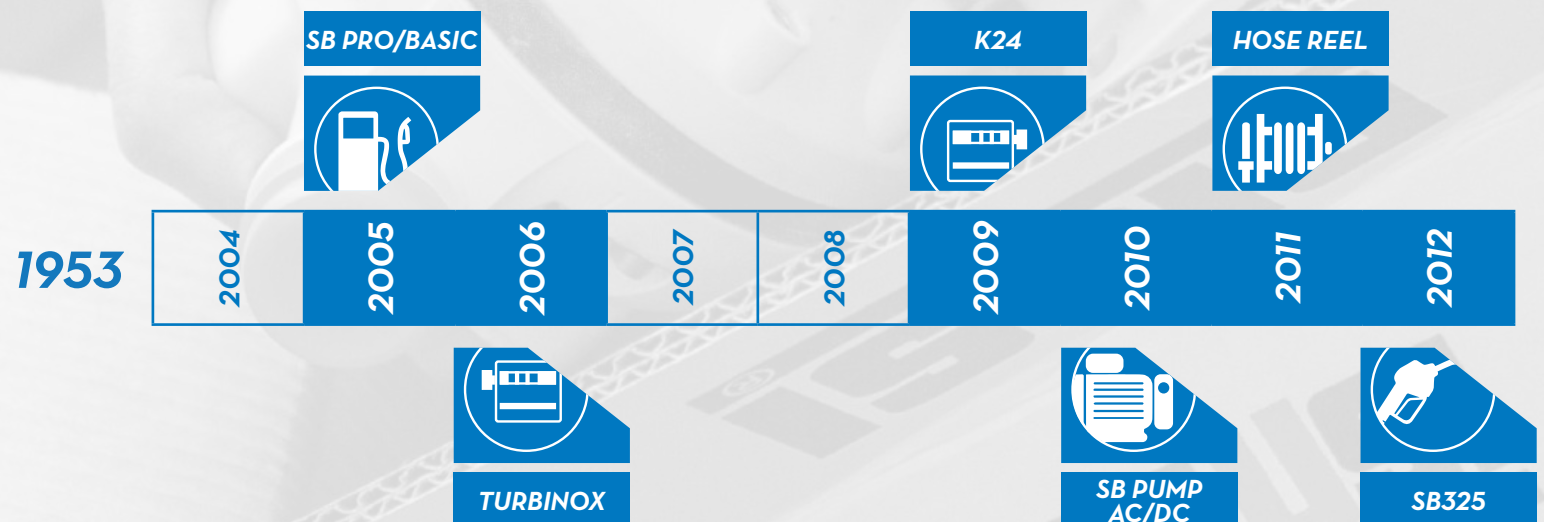

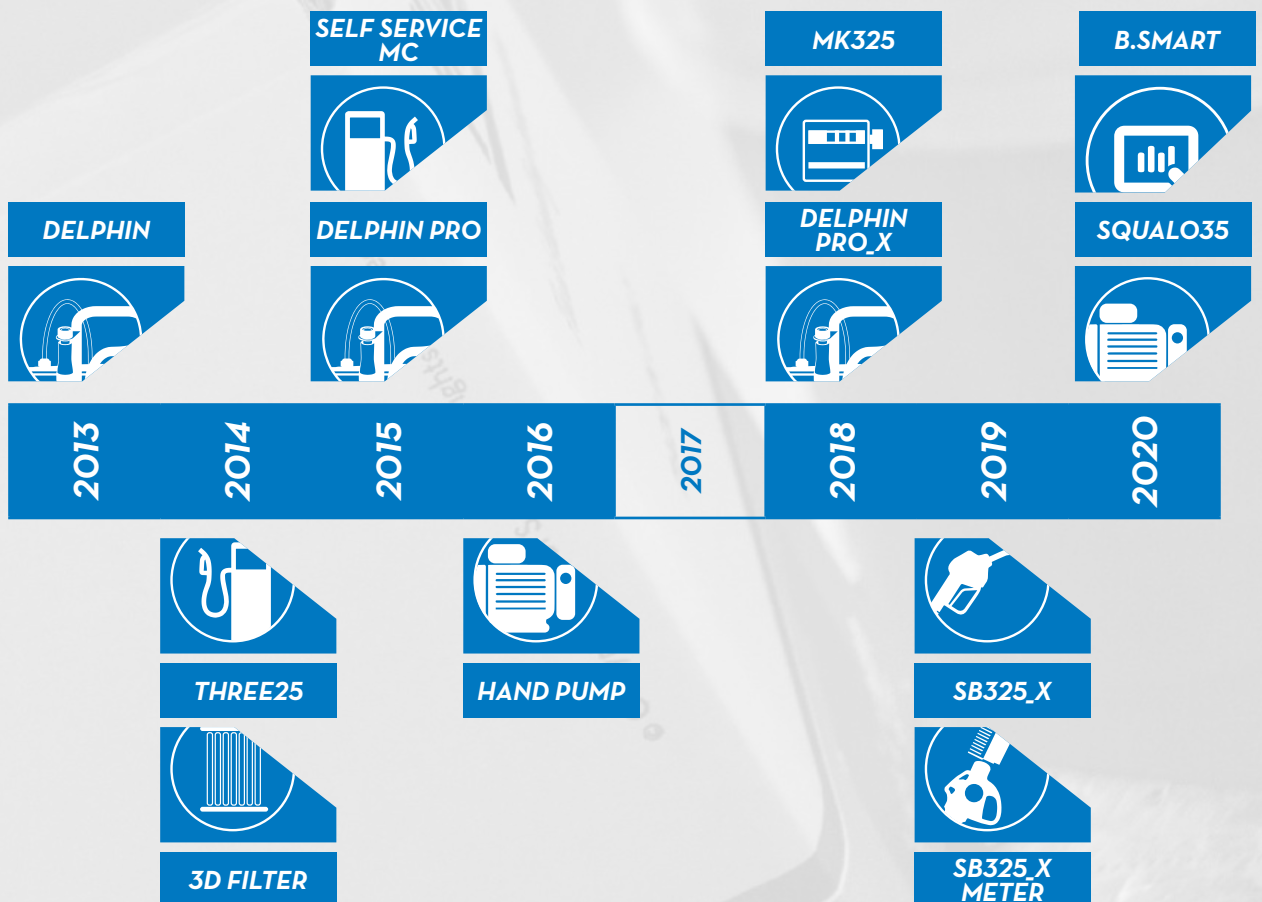



CAR FILLING

A large, solid red triangle is positioned in the bottom right corner of the page, pointing towards the top right.



CAR FILLING



FUEL MANAGEMENT SYSTEMS



KITS



PUMPS



METERS



METERED NOZZLES

DELPHIN PRO_X

FEATURES

- FULLY AUTOMATIC
- 100% COMPATIBLE WITH ALL CARS AND VEHICLES**
- AUTOMATIC FLOW RATE REGULATION
- PRESET QUANTITY

DELPHIN PRO_X is the latest innovation within the PIUSI AdBlue® car filling equipment: preset function, automatic FLOW RATE regulation and visual diagnostic alert are just few of its main new features. This dispenser comes both in AC and DC version, and, thanks to the sturdy and adjustable cart, it can easily support 60/200 ltrs drums.

The AUTOMATIC FLOW RATE function adjust the FLOW RATE according to the vehicle's tank. While the PRESET allow to pre-define the total amount of AdBlue® to be filled in the car tank.

PERFORMANCE

2-15 L/MIN

FLOW RATE

AC/DC
VOLTAGE

POWER

2M

HOSE LENGTH



DELPHIN PRO_X



PACKAGING

CODE	WEIGHT		PACKAGING			
	KG	LBS	MM	INCH	PCS/PALLET	PCS/BOX
FO0100400	43,5	96	770X1080X800	30,3X42,1X31,5	4	1
FO0100410	51	112,5	770X1080X800	30,3X42,1X31,5	4	1



NOZZLES



FILTRATION



TANK MONITORING



HOSE REEL



ACCESSORIES



MERCHANDISE

INDEX



AIR



ANTIFREEZE



AdBlue®



BIODIESEL



DIESEL



FOOD



GASOLINE



GREASE



KEROSENE



OIL



WATER



WINDSCREEN

FUNCTIONING



AUTOMATIC FLOW RATE

The fastest automatic way to refill any car. Thanks to this option, DELPHIN PRO_X automatically adjust the flow rate accordingly to the vehicle's tank.



PRESET

By pre-setting the needed quantity the operator can concentrate on something else while DELPHIN PRO_X is refilling. DELPHIN PRO_X will stop automatically when the preset quantity will be reached.

IN THE BOX

- DELPHIN PRO_X UNIT
- AF2 CONNECTOR
- INSTRUCTION MANUAL

DETAILS



UNIVERSAL ISO CONNECTOR



AF2 CONNECTOR

DIMENSIONS

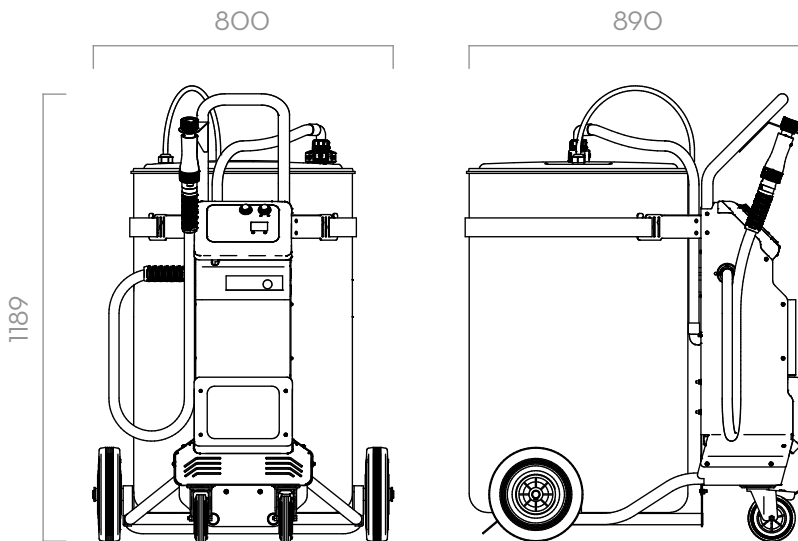

Dimensions expressed in millimeters

MATERIALS

- PUMP:
- BODY: POLIPROPYLENE
- DIAPHRAGM: POLIPROPYLENE

TECHNICAL DATA

CODE	DESCRIPTION	FLUIDS TYPE	FLOW RATE		VOLTAGE			HOSE		ON/OFF
			L/MIN	GPM	AC V./HZ DC VOLT	POWER WATT	AMP. MAX.	LENGHT	Ø	SWITCH
FO0100400	DELPHIN PRO_X AC		2 - 15	0,5 - 4	230/50	200	1,1	2 M	3/4"	YES
FO0100410	DELPHIN PRO_X DC		2 - 15	0,5 - 4	230/50*	200*	1,1	2 M	3/4"	YES

* BATTERY CHARGER

**IN ACCORDANCE TO ISO/FDIS 22241-4:2009



CAR FILLING



FUEL MANAGEMENT SYSTEMS



KITS



PUMPS



METERS



METERED NOZZLES

DELPHIN PRO

FEATURES

- FULLY AUTOMATIC
- NO OPERATOR NEEDED
- 100% COMPATIBLE WITH ALL CARS AND VEHICLES**
- STURDY DESIGN
- EASY TO HANDLE
- FLOW RATE REGULATOR

DELPHIN PRO is the most famous PIUSI AdBlue® car filling system: it allows any garage to enter into the automatic car filling of AdBlue® stopping the use of manual tanks. Compact, mobile, reliable and robust, DELPHIN PRO can be used in every working condition. It is fully automatic - it will only take 2 minutes for a full AdBlue® tank - and its patented spout prevents AdBlue® from crystallizing and never requires cleaning or servicing.

PERFORMANCE

2-11 L/MIN

FLOW RATE

AC
VOLTAGE

POWER

2M

HOSE LENGTH



DELPHIN PRO



PACKAGING

CODE	WEIGHT		PACKAGING		
	KG	LBS	MM	INCH	PCS/BOX
FO010020B	37	81,5	770X1080X800	30,3X42X31,5	1
FO010021B	37	81,5	770X1080X800	30,3X42X31,5	1



NOZZLES



FILTRATION



TANK MONITORING



HOSE REEL



ACCESSORIES



MERCHANDISE

INDEX



AIR



ANTIFREEZE



AdBlue®



BIODIESEL



DIESEL



FOOD



GASOLINE



GREASE



KEROSENE



OIL



WATER



WINDSCREEN

FUNCTIONING



ACTIVATE
DELPHIN PRO



USE THE DIMMER
TO ADJUST
THE FLOW RATE



CONNECT THE
CONNECTOR
TO THE TANK
OF THE CAR



PRESS THE
REFILL BUTTON
FOR 5 SECS



ONCE THE TANK IS
FULL, DELPHIN PRO
AUTOMATICALLY
STOPS DISPENSING

IN THE BOX

- DELPHIN PRO UNIT
- AF2/SEC CONNECTOR
- INSTRUCTION MANUAL

DETAILS



UNIVERSAL ISO CONNECTOR



SEC VERSION AVAILABLE

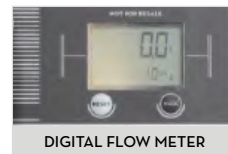

DIGITAL FLOW METER

DIMENSIONS

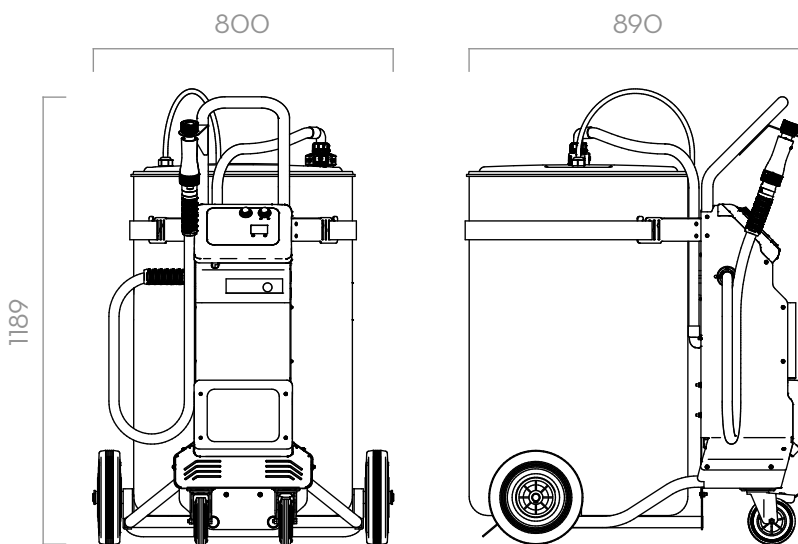

Dimensions expressed in millimeters

MATERIALS

- PUMP:
- BODY: POLIPROPYLENE
- DIAPHRAGM: POLIPROPYLENE

TECHNICAL DATA

CODE	DESCRIPTION	FLUIDS TYPE	FLOW RATE		VOLTAGE			HOSE		ON/OFF
			L/MIN	GPM	AC V./HZ DC VOLT	POWER WATT	AMP. MAX.	LENGHT	Ø	SWITCH
FO010020B	DELPHIN PRO 120/230V-50/60HZ		2 - 11	0,5 - 2,9	230/50	200	1,1	2 M	3/4"	YES
FO010021B	DELPHIN PRO 120/230V-50/60HZ W/SEC CONN		2 - 11	0,5 - 2,9	230/50	200	1,1	2 M	3/4"	YES

**IN ACCORDANCE TO ISO/FDIS 22241-4:2009



CAR FILLING



FUEL MANAGEMENT SYSTEMS



KITS



PUMPS



METERS



METERED NOZZLES

DELPHIN PRO IBC

FEATURES

- FULLY AUTOMATIC
- 100% COMPATIBLE WITH ALL CARS AND VEHICLES**
- STURDY DESIGN
- EASY TO INSTALL
- FLOW RATE REGULATOR
- SPECIFICALLY DESIGN FOR IBC TANKS

DELPHIN PRO IBC is a compact and professional solution for an AdBlue® car filling fixed installation. It benefits from all the features of Delphin Pro AC while being suitable for all situations with a higher consumption of AdBlue®. It is designed to be hung on IBC tanks guaranteeing maximum security and reliability thanks to the lock bracket system. The integrated handle allows a safe and easy lifting. The flat bottom allows to place DELPHIN PRO IBC firmly on the floor during the IBC tank replacement or any other operation.

PERFORMANCE

2-11 L/MIN

FLOW RATE

AC
VOLTAGE
POWER

6M

HOSE LENGTH

AVAILABLE WITH
ON/OFF
BUTTON
SWITCH



DELPHIN PRO IBC



PACKAGING

CODE	WEIGHT		PACKAGING		
	KG	LBS	MM	INCH	PCS/BOX
FO0100BOA	24	52,9	500X340X590	19,7X13,4X23,2	1



NOZZLES



FILTRATION



TANK MONITORING



HOSE REEL



ACCESSORIES



MERCHANDISE

INDEX



AIR



ANTIFREEZE



AdBlue®



BIODIESEL



DIESEL



FOOD



GASOLINE



GREASE



KEROSENE



OIL



WATER



WINDSCREEN

FUNCTIONING



1
ACTIVATE
DELPHIN PRO



2
USE THE DIMMER
TO ADJUST
THE FLOW RATE



3
CONNECT THE
CONNECTOR
TO THE TANK
OF THE CAR



4
PRESS THE
REFILL BUTTON
FOR 5 SECS



5
ONCE THE TANK IS
FULL, DELPHIN PRO
AUTOMATICALLY
STOPS DISPENSING

DIMENSIONS

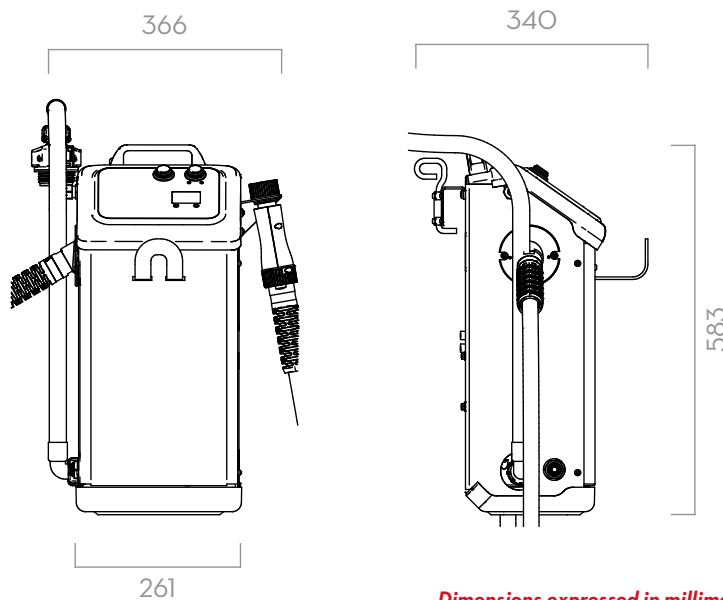

Dimensions expressed in millimeters

IN THE BOX

- DELPHIN PRO IBC UNIT
- AF2 / SEC CONNECTOR
- INSTRUCTION MANUAL

DETAILS



UNIVERSAL ISO CONNECTOR



AF2 CONNECTOR INCLUDED



SEC VERSION INCLUDED



DIGITAL FLOW METER

MATERIALS

- PUMP:
BODY: POLIPROPYLENE
DIAPHRAGM: POLIPROPYLENE

TECHNICAL DATA

CODE	DESCRIPTION	FLUIDS TYPE	FLOW RATE		VOLTAGE			HOSE		ON/OFF
			L/MIN	GPM	AC V./HZ	POWER WATT	AMP. MAX.	LENGHT (M)	Ø (MM)	SWITCH
FO0100BOA	DELPHIN PRO IBC AF2-SEC 230V/50HZ		2 - 11	0,5 - 2,9	230/50	200	1,1	3	19	YES

**IN ACCORDANCE TO ISO/FDIS 22241-4:2009



CAR FILLING



FUEL MANAGEMENT SYSTEMS



KITS



PUMPS



METERS



METERED NOZZLES

FLIPPER

FEATURES

- COMPLETE KIT
- READY TO USE
- COMPATIBLE WITH ALL VEHICLES
- ROBUST, FUNCTIONAL
- 3D FILTER FOR ADBLUE
- SB325_X METER NOZZLE CAR VERSION

FLIPPER is the AdBlue® mobile transfer trolley made by PIUSI. It is light and handy with switching from manual to electric operation to save time, money and effort.

PERFORMANCE

20 L/MIN

FLOW RATE

230V
VOLTAGE

POWER

6M

ELECTRIC CABLE

2,2M

HOSE LENGTH



FLIPPER

PACKAGING

CODE	WEIGHT		PACKAGING			
	KG	LBS	MM	INCH	PCS/PALLET	PCS/BOX
FO0100COA	44	97	1070X700X300	42,1X27,5X11,8	1	1



NOZZLES



FILTRATION



TANK MONITORING



HOSE REEL



ACCESSORIES



MERCHANDISE

INDEX



AIR



ANTIFREEZE



AdBlue®



BIODIESEL



DIESEL



FOOD



GASOLINE



GREASE



KEROSENE



OIL



WATER



WINDSCREEN

FUNCTIONING

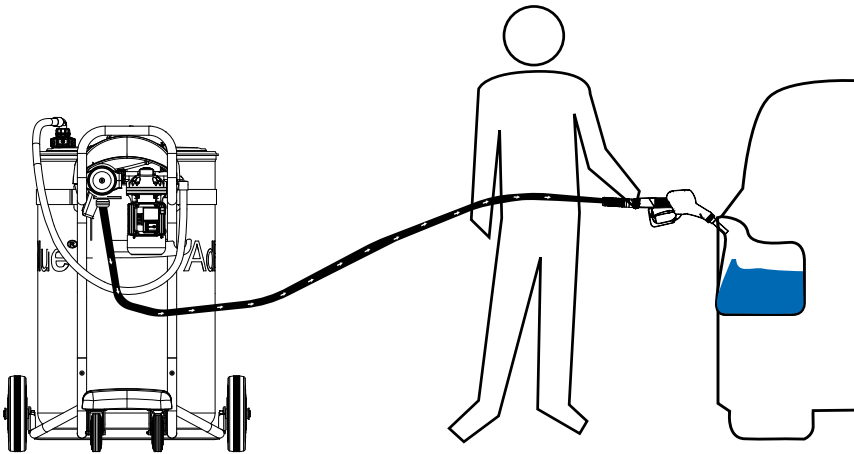

IN THE BOX

- FLIPPER UNIT
- CART
- AF2 CONNECTOR
- SUCTION HOSE
- DELIVERY HOSE
- SB325_X METER NOZZLE CAR
- INSTRUCTION MANUAL

DETAILS



3D FILTER



AF2 CONNECTOR



SB325_X METER CAR



BENDING PROTECTION

DIMENSIONS

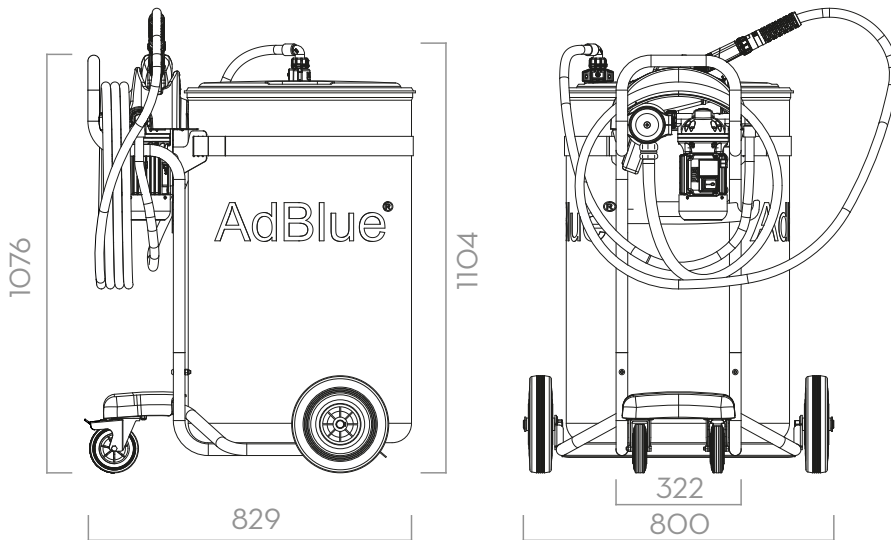

Dimensions expressed in millimeters

COMPONENTS

- PUMP:
SUZZARABLU PUMP AC
- FILTER:
3DFILTER

TECHNICAL DATA

CODE	DESCRIPTION	FLUIDS TYPE	FLOW RATE		VOLTAGE			HOSE		ON/OFF
			L/MIN	GPM	AC V./HZ DC VOLT	POWER WATT	AMP. MAX.	LENGHT	Ø	SWITCH
FO0100COA	FLIPPER AC 230V 50 HZ		20	0,5 - 2,6	230/50	400	1,95	2,2	3/4"	YES



CAR FILLING



FUEL MANAGEMENT SYSTEMS



KITS



PUMPS



METERS



METERED NOZZLES

EDGARD

FEATURES

- MOBILE TROLLEY
- COMPATIBLE WITH CARS AND COMMERCIAL VEHICLES
- STURDY AND FUNCTIONAL
- SB325_X CAR NOZZLE
- SIMPLE AND INTUITIVE CONTROL PANEL

Born from PIUSI experience into the AdBlue® refilling equipment, EDGARD is a mobile system, battery powered, expressly engineered to dispense AdBlue® into cars and commercial vehicles.

Practical and movable, it is specifically designed for all the service stations that need a handy equipment for a guaranteed sale of AdBlue® by volume.

PERFORMANCE

5-12 L/MIN

FLOW RATE

**100-240V
50/60HZ**

VOLTAGE

19 MM

NOZZLE SPOUT

2 MT

LENGHT DELIVERY HOSE



EDGARD



PACKAGING

CODE	WEIGHT		PACKAGING			
	KG	LBS	MM	INCH	PCS/PALLET	PCS/BOX
FO0100EOA	40		1200X800X960		1	-



NOZZLES



FILTRATION



TANK MONITORING



HOSE REEL



ACCESSORIES



MERCHANDISE

INDEX



AIR



ANTIFREEZE



AdBlue®



BIODIESEL



DIESEL



FOOD



GASOLINE



GREASE



KEROSENE



OIL



WATER



WINDSCREEN

FUNCTIONING

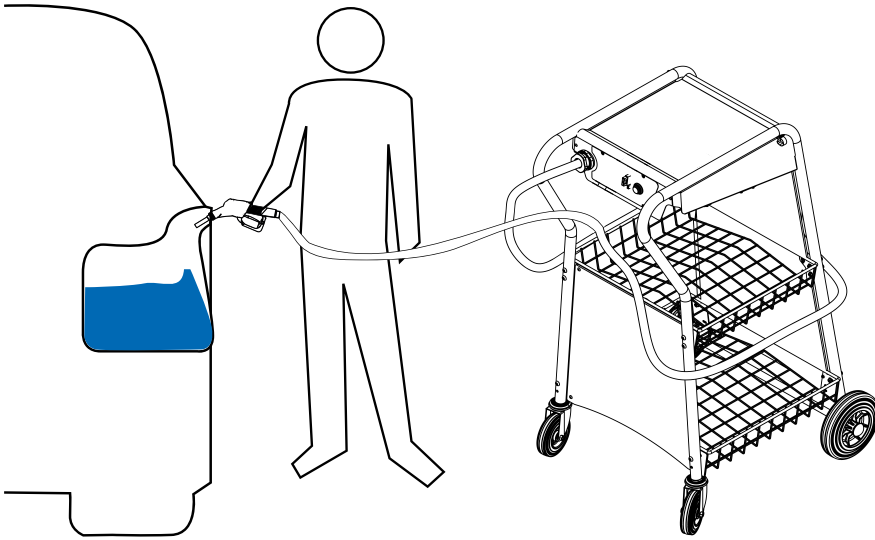

IN THE BOX

- MOBILE TROLLEY WITH SUZZARABLU PUMP DC
- SUCTION/DELIVERY HOSE
- SB325_X CAR NOZZLE
- INSTRUCTION MANUAL

DETAILS



SB325_X METER CAR



CONTROL PANEL



SUZZARABLU PUMP DC

DIMENSIONS

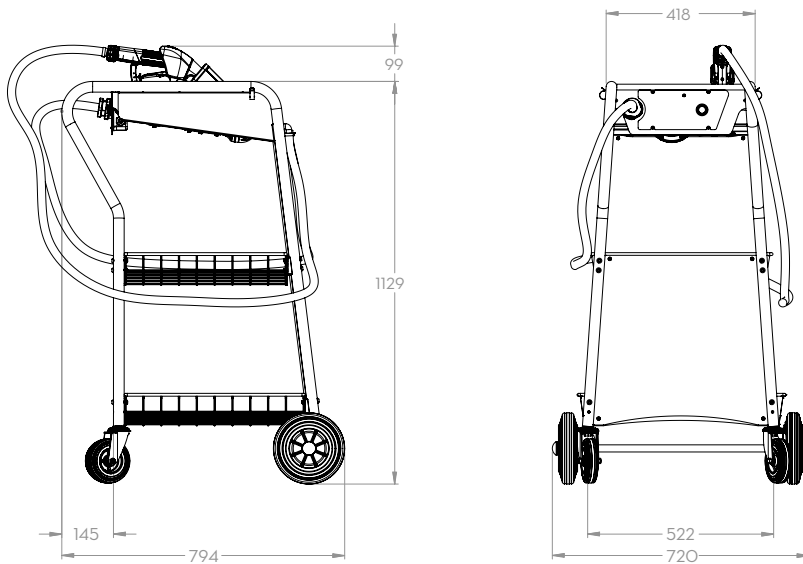

Dimensions expressed in millimeters

MATERIALS

- PUMP:
SUZZARABLU PUMP DC
- NOZZLE:
SB325_X CAR





TECHNICAL DATA





CODE	DESCRIPTION	FLUIDS TYPE	FLOW RATE		VOLTAGE		HOSE			START/STOP
			L/MIN	GPM	AC V/HZ DC VOLT	AMP. MAX.	LENGHT DELIVERY	SUCTION	Ø	
FO0100EOA	EDGARD		5-12	1,3 -3,1	100-240V 50/60HZ	1.2A - 230V / 2.2A - 115V	2M	1,5M	16MM	Si









CAR FILLING ACCESSORIES

FILLING SYSTEMS

DELPHIN PRO_X	CODE	DESCRIPTION	
	F21614000	TANK RECOVERY SYSTEM DELPHIN PRO	   
	F2142100A	ADAPTER 3/4" 70X6 DELPHIN	
	F15452000	SEC + HOSETAIL 90°	
	F20189000	AF2 56X4 BUTTRESS - 1" BSP	
	F20190000	AF2 2" BUTTRESS - 1" BSP	
	F20257000	AF2 2" BSP - 1" BSP	
	F20258000	AF2 2" 70X6 - 1" BSP	

DELPHIN PRO	CODE	DESCRIPTION	
	F20189000	AF2 56X4 BUTTRESS - 1" BSP	  
	F20190000	AF2 2" BUTTRESS - 1" BSP	
	F20257000	AF2 2" BSP - 1" BSP	
	F20258000	AF2 2" 70X6 - 1" BSP	
	F21614000	TANK RECOVERY SYSTEM DELPHIN PRO	
	F2142100A	ADAPTER 3/4" 70X6 DELPHIN	
	F15452000	SEC + HOSETAIL 90°	

DELPHIN PRO IBC	CODE	DESCRIPTION	
	F20189000	AF2 56X4 BUTTRESS - 1" BSP	   
	F20190000	AF2 2" BUTTRESS - 1" BSP	
	F20257000	AF2 2" BSP - 1" BSP	
	F20258000	AF2 2" 70X6 - 1" BSP	
	F12511000	VAPOUR RECOVERY DELPHIN PRO IBC	
	F2193800A	AF2 56X4 BUTT. - 1" BSP SUCTION CONNECTOR	
	F2193900A	AF2 2" BSP - 1" BSP SUCTION CONNECTOR	

FLIPPER	CODE	DESCRIPTION	
	F00611D40	PIUSI 3D FILTER CARTRIDGE	





FUEL MANAGEMENT SYSTEMS

A large, solid red triangle is positioned in the bottom right corner of the page, pointing towards the top left. It is a simple, flat color with no text or other details inside it.



CAR FILLING



FUEL MANAGEMENT SYSTEMS



KITS



PUMPS



METERS



METERED NOZZLES

OVERVIEW

FEATURES:

ACCURATE DATA

• REAL AND ACCURATE CONSUMPTIONS' DATA ON EACH REFUELLING OPERATION MANAGED AUTOMATICALLY BY THE SYSTEM;

• OVERVIEW ON CONSUMPTIONS' TREND AND AVAILABLE RESIDUAL AdBlue®/DEF;

REDUCED COSTS

• CAREFUL AND MEASURED CONSUMPTION OF AdBlue®/DEF ALLOWS TO SAVE UP TO 10% OF FLUID EVERY YEAR

NO ABUSE

• A FUEL MANAGEMENT SYSTEM ALLOWS YOU TO TRACK WHO IS MAKING THE PROCEDURE, ON WHICH VEHICLE ALSO INDICATING THE DISPENSER USED IN ORDER TO CONTAIN ABUSES.

Fuel Management Systems (FMS) are technologically-advanced equipment that allow to measure, control and manage the consumptions of AdBlue®/DEF (or other fluids) of fleets or other Company vehicles (such as for example the earth moving machines within the construction industry).

The consumption of AdBlue®/DEF and fuel is an important part of the running costs of a fleet.

How much AdBlue®/DEF have you wasted in the past few months?

How much AdBlue®/DEF does each vehicle or driver consume?

What was the trend of consumptions?

To have a clear and precise overview on the situation, you need a FMS.

A system linked to your dispensers and stations for AdBlue®/DEF transferring that follow and trace all the refuelling operations also indicating who is the operator and the vehicle which is refuelled; all in real time.

PIUSI has developed 3 different FMS software for AdBlue®/DEF suitable for all different requirements: B.SMART, SSM 2.0 and SELF SERVICE MANAGEMENT AGILIS.

AGILIS
SELSERVICE
MANAGEMENT



B.SMART



SSM 2.0
SELF SERVICE MANAGEMENT





NOZZLES



FILTRATION



TANK MONITORING



HOSE REEL



ACCESSORIES



MERCHANDISE

INDEX



AIR



ANTIFREEZE



AdBlue®



BIODIESEL



DIESEL



FOOD



GASOLINE



GREASE



KEROSENE



OIL



WATER



WINDSCREEN

Why choose a PIUSI FMS?

With **70 years of history**, PIUSI can supply not only all the technological and IT aspects of the software, but also - integrated - a wide range of dispensers suitable for all needs.

By choosing PIUSI, you will have - from a single supplier - not only the **Software**, but also the **dispensing Hardware** directly from the same **Company**.

GENERAL	PLATFORM
	MULTISITE
	MAX USERS
	MAX DISPENSERS
	USER LOGIN
LIMIT SETTINGS	REMOTE USER/DISPENSER DEACTIVATION
	USER DAY/WEEKLY LIMITS
	VEHICLE LIMITS
MANAGEMENT: • VEHICLES • SUPPLIERS • CONSUMPTIONS	REGISTRATION NUMBER
	USER VEHICLE ASSIGNMENT
	ODOMETER
	EXTERNAL TRANSACTIONS
	FUEL CONSUMPTION MANAGEMENT
	ADBLUE CONSUMPTION MANAGEMENT
	FLUID SUPPLIERS MANAGEMENT
TANK LEVEL MANAGEMENT	TANK LOW LEVEL PUMP CUT-OFF
	REMOTE TANK LEVEL MANAGEMENT
	MAX NO. OCIO
TANK ALARM	SOFTWARE ALARMS
	HARDWARE ALARMS (W/OCIO)
REPORT	TRANSACTION REPORT
	TANK LEVEL REPORT
	FUEL PRICE TREND REPORT

AGILIS
SELF SERVICE
MANAGEMENT

Dispensing control ideal for:
company that wants to monitor the quantity delivered.

PC Software

-

250/dispenser

16

iButton/PinCODE

-

-

-

Manual entry

-

JA

-

-

-

-

YES

YES

-

YES

YES

YES

-

-

SSM 2.0
SELF SERVICE MANAGEMENT

Consumption control ideal for:
a company that wants to monitor and manage the quantities supplied, manage consumption and supply of fuels.

PC Software

with PW mobile

up to 1000

up to 20

iButton/Pincode

YES

YES

YES

iButton

YES

YES

YES

YES

YES

YES

YES

YES

up to 20

YES

YES

YES

YES

YES

B.SMART

Dispensing control ideal for:
company that wants to monitor and manage the quantities delivered in the cloud without territorial limitations, with smart technologies.

Cloud Software

YES

Unlimited

Unlimited

Mobile App*

YES

with Fuel Economy Add-on

with Fuel Economy Add-on

Mobile App

YES

YES

with Fuel Economy Add-on

with Fuel Economy Add-on

with Fuel Economy Add-on

with Tank Watchdog Add-on

YES

with Tank Watchdog Add-on

Unlimited - with Tank Watchdog Add-on

YES

YES

YES

with Tank Watchdog Add-on

with Tank Watchdog Add-on

*IBUTTON: IN CASE OF EMERGENCY IF/OR SMARTPHONE IS ABSENT OR IT DOESN'T WORK



CAR FILLING



FUEL MANAGEMENT SYSTEMS



KITS



PUMPS



METERS



METERED NOZZLES

B.SMART

FEATURES

- SIMPLE, INTUITIVE, SUITABLE FOR EVERYONE
- UNLIMITED TO FIT ALL NEED
- MONO OR MULTI-SITE
- SOFTWARE ALWAYS INCLUDED WITH THE DISPENSER
- BLUETOOTH
- CLOUD-BASED
- NO SOFTWARE INSTALLATION
- NO FEE
- ANALYSIS, CONTROL AND MANAGEMENT IN ONE CLICK

B.SMART is the Fuel Management System (FMS) by PIUSI designed and engineered for fleets of all sizes: small, medium, large, mono or multi-site. Innovative, simple and smart - the name carries its meaning - PIUSI B.SMART combines the quality and efficiency of PIUSI dispensers, with a Cloud-based software (APP for drivers and a web APP for fleet managers) driven by Bluetooth technology; that means no Wi-Fi or LAN network are required. Thus, it is possible to use B.SMART wherever; also in the more distant areas. A FMS all in one: the fleet manager has just to choose the necessary dispensers; the software is always included in the "package" (no rental ore recurring fee will be required).

PERFORMANCE

<p>DATA</p> <p>AVAILABLE</p> <p>ALWAYS</p> <p>TRANSACTIONS</p>	<p>NO</p> <p>SOFTWARE</p> <p>ON THE PC</p> <p>CLOUD</p>
<p>NO FEE</p> <p>UTILIZATION</p>	<p>ONLY</p> <p>BLUETOOTH</p> <p>NO WI-FI OR LAN</p> <p>CONNECTION</p>



B.SMART

B.SMART is flexible and expandable: the same system easily fits to all requirements. It is only necessary to add the add-on needed to keep up with the evolution of the fleet.

B.SMART API AVAILABLE

CONNECT YOUR ERP TO B.SMART WITH THE INTEGRATED API INTERFACE.

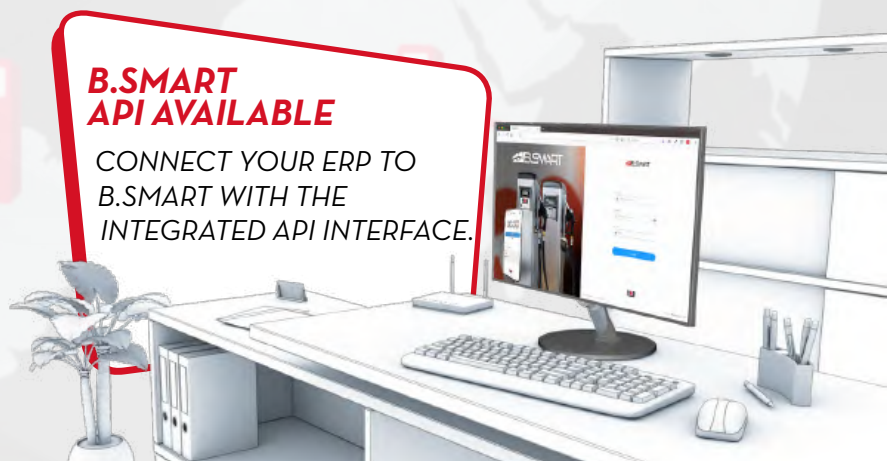
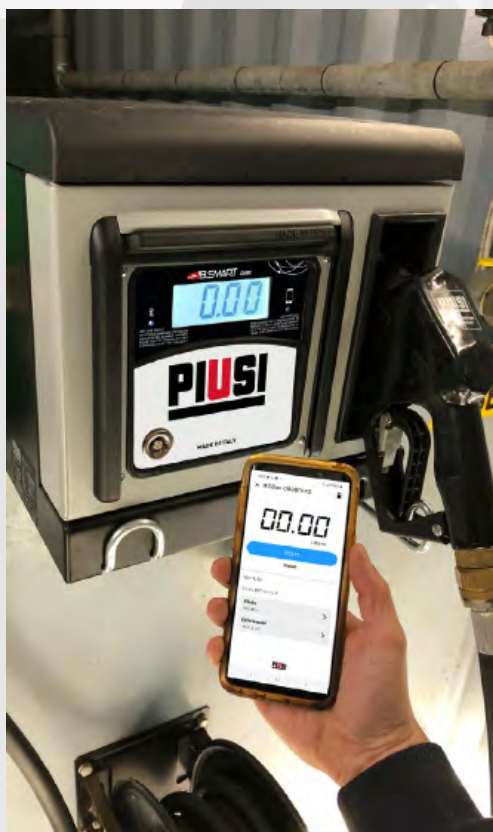



NOZZLES



FILTRATION



TANK MONITORING



HOSE REEL



ACCESSORIES



MERCHANDISE

INDEX



AIR



ANTIFREEZE



AdBlue®



BIODIESEL



DIESEL



FOOD



GASOLINE



GREASE



KEROSENE



OIL



WATER



WINDSCREEN



APP

Dedicated to drivers, the APP for drivers just needs a smart device with Bluetooth to work properly: once the APP is open, the smartphone or tablet immediately connects to the dispenser to start the refueling operation.



HARDWARE

PIUSI B.SMART runs only with the dedicated range of dispensing devices: quality guaranteed by PIUSI; the highest technical performances and reliability, all form a unique supplier. Real time communication between the dispenser and the PC.



CLOUD

The core of B.SMART fuel management software is a Cloud-based service that tracks every refuelling operation and keeps every device synchronized.

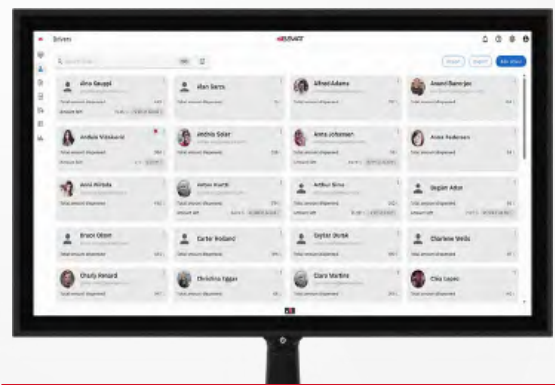

WEB APP

Dedicated to fleet manager. No software installation: just log in and start immediately to monitor, manage and control consumptions of the fleet.



CAR FILLING



FUEL MANAGEMENT SYSTEMS



KITS



PUMPS



METERS



METERED NOZZLES

ADD-ONS

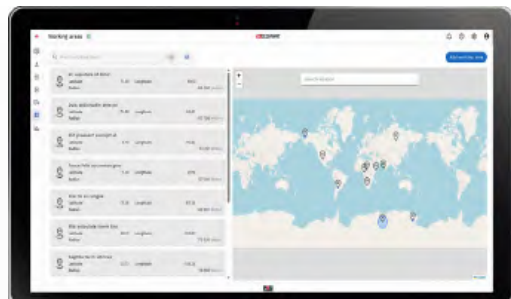

ADD-ON

Once the ADD-ON is chosen, PIUSI will send an activation code with all related instructions.

DRIVER ADD-ON

CODE	DESCRIPTION
F22500000	DRIVER ACCESS ADD-ON B.SMART (X10)
FO0770D20	DRIVER ACCESS ADD-ON B.SMART (X50)

TANK WATCHDOG

B.SMART Tank Watchdog is the perfect add on for a complete and updated control of the stock. It allows you to:

- monitor the tank level (add fluid loads and unloads and adjustments);
- set level alarms;
- manage suppliers;
- follow inventory price values and trends;
- access and download reports from anywhere

TANK WATCHDOG ADD-ON

CODE	DESCRIPTION
FO0770L00	B.SMART TANK WATCHDOG ADD-ON - 1 YEAR
FO0770L20	B.SMART TANK WATCHDOG ADD-ON - ONE TIME FEE

Tank levels

Adding the level indicator OCIO, the system allows you to monitor the fluid level in your tanks in real time and gives alarms in case of malfunction or low levels. A perfect add-on for a complete and updated control of the stock. You can connect also any 420 mA o 0-10 V fluid gauge or run the system without any gauge thanks to the “virtual tank” option:

- set level alarms and get notifications on the tank level;
- possibility to configure high level or low level alarms;
- stop the pump according to the level of the fluid;
- send an automatic e-mail to notify when you reach the level alarm set.

Fluid price and values

Thank to the level indicator OCIO you can have at your fingertips the fluid inventory value & quantity: you can define the refuelling price and verify the current inventory value.

- manage suppliers of the fluids to keep track of the date, price and quantity bought;
- get real time data of the value of your inventory;
- follow fluids price trends;
- access and download reports from any internet connected device thanks to the software cloud.

FUEL ECONOMY

Enhance your system and become even more smart with the Fuel Economy ADD-ON for B.SMART! Thanks to this new module, you can now completely manage and increase the profitability of your fleet:

- manage consumptions, cross-checking vehicles and drivers;
- manage drivers' and vehicles' limits;
- add, check and manage the on-road refuellings.

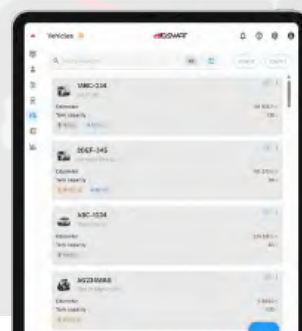



NOZZLES



FILTRATION



TANK MONITORING



HOSE REEL



ACCESSORIES



MERCHANDISE

INDEX



AIR



ANTIFREEZE



AdBlue®



BIODIESEL



DIESEL



FOOD



GASOLINE



GREASE



KEROSENE



OIL



WATER



WINDSCREEN

Fleet management & limits

Thanks to this new add-on, you can:

- add to the B.SMART WEB APP system all the vehicles of your fleet;
- group all the vehicles according to a specific and personalized setting;
- add to the WEB APP the images of your vehicles and drivers for a quickest and easy identification;
- set drivers and vehicles limits based on quantities or time frames

FUEL ECONOMY ADD-ON

CODE	DESCRIPTION
FO0770FOO	B.SMART FUEL ECONOMY ADD-ON 1 YEAR
FO0770F20	B.SMART FUEL ECONOMY ADD-ON ONE TIME FEE
F17299Q00	B.SMART FUEL ECONOMY 45 QR CODES

Consumptions report

Thanks to this new add-on, you can have detailed reports of:

- fuel/AdBlue® dispenses;
- vehicles' consumptions, spotting deviations vs standard;
- drivers' consumption on vehicles, tracking the driving behaviour of the operator;
- spot drivers' high fuel consumption;
- add on-road transactions highlighting also fuel/AdBlue® costs and the service station used in order to have a complete overview on the trend/activities of both drivers and vehicles.

MAPLY

The add-on is specifically designed for companies working in construction, mining, excavation, drilling, landscaping or agriculture that want to have all the information at-a-glance including GPS location of fuel dispensing. With Maply Add-on it is possible:

- reduce fuel waste
- increase company profitability
- monitor & control fuel dispensing

Geolocation

- Geolocate fuel transactions and display them on a map;
- "report on map" gives an overview of fuel dispensing. Clicking on a fuel transaction you get all the relevant data (quantity, date, time, vehicle refuelled, etc.)

Manage fluid handover from fixed to mobile tanks

- Automatically manage portable tank loads;
- fuel transfer information will be managed inside the B.Smart reporting system, increasing information effectiveness.

3rd parties vehicles refuelling

- Track fuel transactions on third-party vehicles;
- possibility to send e-mail notifications and add operator's notes.

MAPLY ADD-ON

CODE	DESCRIPTION
FO0770M00	B.SMART MAPLY ADD-ON - 1 YEAR
FO0770M20	B.SMART MAPLY ADD-ON - ONE TIME FEE

AVAILABLE KITS ADD-ON

KIT ADD-ON

CODE	DESCRIPTION
FO0770K00	KIT TANK WATCHDOG + FUEL ECONOMY 1 YEAR
FO0770K20	KIT TANK WATCHDOG + FUEL ECONOMY ONE TIME FEE
FO0770K40	KIT TANK WATCHDOG + FEM + MAPLY 1 YEAR
FO0770K60	KIT TANK WATCHDOG + FEM + MAPLY ONE TIME FEE



CAR FILLING



FUEL MANAGEMENT SYSTEMS



KITS



PUMPS



METERS



METERED NOZZLES

SELF SERVICE B.SMART

FEATURES

- ACCESS CONTROL AND MANAGE ADBLUE® DELIVERY
- 3D FILTER INTEGRATED
- COMPACT DESIGN
- NATIVE WITH B.SMART CLOUD SOFTWARE
- KIT UPGRADE 1.0/2018 AVAILABLE

SELF SERVICE B.SMART for AdBlue® is the updated version of the famous PIUSI AdBlue® dispenser integrated with the fuel management system B.SMART! Starting from today, you can manage the consumption of AdBlue® of your fleet with this new and innovative urea dispenser.

PERFORMANCE

UP TO

32 L/MIN

FLOW RATE

VOLTAGE

AC

POWER

±1%

ACCURACY



SELF SERVICE B.SMART

PACKAGING

CODE	WEIGHT		PACKAGING			N. BOXES / EUROPALLET	
	KG	LBS	MM	INCH	PCS/BOX	✕	
FO0748020	48	105	1480X490X400	58.3X19.3X15.7	1		



NOZZLES



FILTRATION



TANK MONITORING



HOSE REEL



ACCESSORIES



MERCHANDISE

INDEX



AIR



ANTIFREEZE



AdBlue®



BIODIESEL



DIESEL



FOOD



GASOLINE



GREASE



KEROSENE



OIL



WATER



WINDSCREEN

CHART

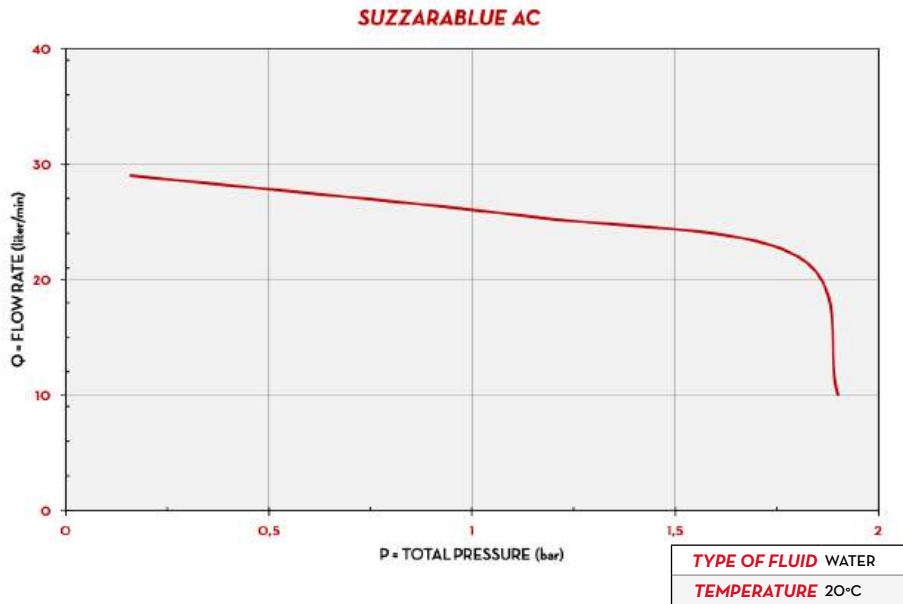

DIMENSIONS

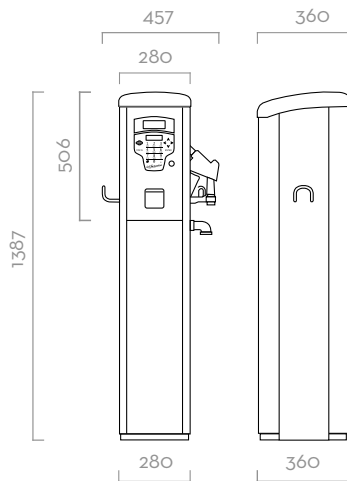

Dimensions expressed in millimeters

IN THE BOX

- SELF SERVICE B.SMART DISPENSER
- DELIVERY HOSE
- SB325_X NOZZLE
- DRIVER ACCESS ADD-ON
- INSTRUCTION MANUAL

DETAILS



3D FILTER



OCIO 2.0 ON REQUEST



B.SMART CLOUD SOFTWARE

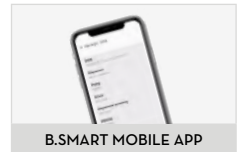

B.SMART MOBILE APP

COMPONENTS

- **PUMP:**
SUZZARABLU PUMP AC
- **METER:**
K24
- **NOZZLE:**
SB325_X
- **FILTER:**
3D FILTER

TECHNICAL DATA

CODE	DESCRIPTION	FLUIDS TYPE	FLOW RATE		VOLTAGE			PUMP	METER	NOZZLE	FILTER	INLET	HOSE		
			L/MIN	GPM	AC V/HZ	DC VOLT	POWER WATT						AMP. MAX.	TYPE	LENGTH
FO0748020	SELF SERV ADBLUE 230V B.SMART 10 ACCESS		34	8,9	230 V	50 HZ	400 W	1.95 A	SUZZARABLU AC	K24	SB325_X	YES	3/4"	6 M	1"



CAR FILLING



FUEL MANAGEMENT SYSTEMS



KITS



PUMPS



METERS



METERED NOZZLES

MCBOX B.SMART

FEATURES

- IDEAL FOR EXISTING PLANTS
- SUITABLE FOR ANY PUMP
- PULSE METER INPUT
- NATIVE WITH B.SMART CLOUD SOFTWARE
- AVAILABLE IN COMPACT VERSION

MCBOX B.SMART is the new advanced system for controlling and monitoring AdBlue® dispensing, compatible with AC/DC pumps, pulse meters, and nozzle contact. Integrated with PIUSI B.SMART, it is ideal for agriculture, automotive, logistics, and industry. Also available in a compact version for installations in confined spaces.

PERFORMANCE

VOLTAGE

AC/DC

POWER

UP TO

500

STORABLE

TRANSACTIONS



MCBOX B.SMART



MCBOX B.SMART COMPACT

PACKAGING

CODE	WEIGHT		PACKAGING		
	KG	LBS	MM	INCH	PCS/BOX
FO0599C00	2,3	5	260X240X170	10,2X9,4X6,6	1
FO0599C10	2,5	5,5	260X240X170	10,2X9,4X6,6	1
FO0599000	5,2	11,5	300X300X180	11,8X11,8X7,1	1
FO0599200	5,2	11,5	300X300X180	11,8X11,8X7,1	1
FO0599060	5,4	11,8	300X300X180	11,8X11,8X7,1	1



NOZZLES



FILTRATION



TANK MONITORING



HOSE REEL



ACCESSORIES



MERCHANDISE

INDEX



AIR



ANTIFREEZE



AdBlue®



BIODIESEL



DIESEL



FOOD



GASOLINE



GREASE



KEROSENE



OIL



WATER



WINDSCREEN

CONNECTION SCHEME



SUZZARABLU PUMP AC



K24 PULSE METER



OCIO



NOZZLE SWITCH WITH SB325_X



IN THE BOX

- MCBOX B.SMART OR MCBOX B.SMART COMPACT
- DRIVER ACCESS ADD-ON
- INSTRUCTION MANUAL

DETAILS



EASY ACCESS TO CONNECTION



OCIO 2.0 ON REQUEST



B.SMART CLOUD SOFTWARE

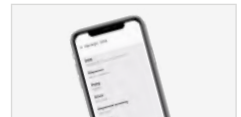

B.SMART MOBILE APP

DIMENSIONS

MCBOX B.SMART

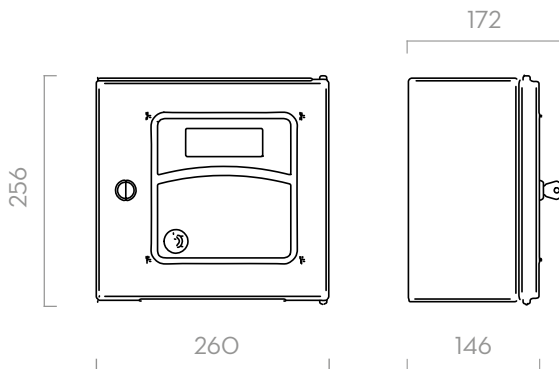

MCBOX B.SMART COMPACT

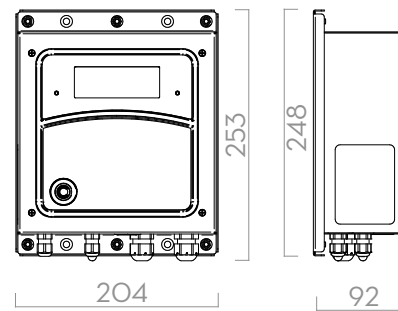

Dimensions expressed in millimeters

TECHNICAL DATA

CODE	DESCRIPTION	FLUIDS TYPE	VOLTAGE				B.SMART CLOUD SOFTWARE/APP
			AC VOLT/HZ DC VOLT	AC VOLT/HZ DC VOLT	POWER WATT	AMP. MAX. (load motor)	
FO0599COO	MCBOX B.SMART 100-240V C 10 ACCESS - COMPACT	A Ad B D F G G K O W W	100-240V	-	5 W	15 A	INCLUDED
FO0599C10	MCBOX B.SMART 12V/24V C 10 ACCESS - COMPACT	A Ad B D F G G K O W W	-	12/24 V	5 W	50/25 A	INCLUDED
FO0599000	MCBOX 100-240V B.SMART 10 ACCESS	A Ad B D F G G K O W W	100-240V	-	5 W	15 A	INCLUDED
FO0599200	MCBOX B.SMART 2 PUMPS - 10 DRIVERS	A Ad B D F G G K O W W	230/50	-	5 W	15A	INCLUDED
FO0599150	MCBOX B.SMART 12V/24V - 10 DRIVERS	A Ad B D F G G K O W W	-	12/24 V	5 W	50/25	INCLUDED



CAR FILLING



FUEL MANAGEMENT SYSTEMS



KITS



PUMPS



METERS



METERED NOZZLES

SSM2.0

FEATURES

- TANK WATCHDOG
- DRIVERS/VEHICLES MANAGEMENT
- REPORT
- FLUID INVENTORY VALUE

The SELF SERVICE MANAGEMENT 2.0 software is the response for management and monitoring of refueling, allowing supervision of drivers, vehicles and fuel tanks. Setting up the system and getting to work has never been easier: simply connect the devices to your LAN or Wi-Fi network and click on the "Detect System" button on your PC. SELF SERVICE MANAGEMENT 2.0 will handle the rest. Use of the SELF SERVICE MANAGEMENT 2.0 software requires the new range of SELF SERVICE 2.0 dispensing devices. The ibutton key reader kit is available on request.

PERFORMANCE

UP TO
1000

DRIVERS / VEHICLES

USB/WEB
SOFTWARE VERSION

INSTALLATION

SOFTWARE ACTIVATION MODE



**USB
HARDWARE KEY**
without internet
connection



**WEB
EDITION**
internet connection
required





NOZZLES



FILTRATION



TANK MONITORING



HOSE REEL



ACCESSORIES



MERCHANDISE

INDEX



AIR



ANTIFREEZE



AdBlue®



BIODIESEL



DIESEL



FOOD



GASOLINE



GREASE



KEROSENE



OIL



WATER



WINDSCREEN

CHECK

The cost of the consumption for every distance.



VIEW

Bar charts easily allow you to analyze the liters delivered each day and compare them with the average use.

VEHICLES

Reads the average consumption and distance driven.



TANK MONITORING

Check the liters delivered over the period you specify.



- The system min. requirements are:
- Monitor resolution 1280x700
- CPU: Intel® Pentium® 4 or AMD Athlon® 64 processor (2 GHz or higher)
- RAM: 2 GB
- Free space on Hard Disk: 20 GB
- Operating system: Windows 10 TH1 1507 or next version, Windows Server 2016 or next version
- Database: Microsoft SQL 2019 CU16
- Express (included in the installation)

TECHNICAL DATA - USB CODE

CODE	DESCRIPTION
FO0772050	SSM 2.0 ENTRY
FO077202A	SSM 2.0 ADVANCED
FO077204A	SSM 2.0 SUITE
FO0772000	SSM 2.0 CLIENT*

TECHNICAL DATA - WEB CODE

CODE	DESCRIPTION
FO0772250	SSM 2.0 ENTRY - WEB EDITION
FO077222A	SSM 2.0 ADVANCED - WEB EDITION
FO077224A	SSM 2.0 SUITE - WEB EDITION
FO0772200	SSM 2.0 CLIENT* - WEB EDITION

* THE PURCHASE OF ADDITIONAL CLIENT LICENSES ENABLES YOU TO USE THE VARIOUS VERSIONS OF SELF SERVICE MANAGEMENT 2.0 ON MULTIPLE WORKSTATIONS.



CAR FILLING



FUEL MANAGEMENT SYSTEMS



KITS



PUMPS



METERS



METERED NOZZLES

DATA TRANSFER SSM2.0

Among the equipment related to SSM 2.0, PIUSI has developed a set of technological solutions able to connect the electronic/mechanical device to the fluid control system, that is the software that organizes the operation of the hardware; in this case SELF SERVICE MANAGEMENT 2.0. How does data transfer with SSM2.0 work? It depends on the technology required.

Direct downloading

Use your Manager Key to transfer the data from dispenser to PC: it is enough to touch the dispenser with the key and then use the key reader to transfer the data collected.

LAN/Wi-Fi

The way to receive in real time all information regarding the transactions: using PWLAN or PW Wi-Fi the software recognizes the fuel dispensers and it will automatically send the data to the SELF SERVICE MANAGEMENT 2.0 software.

Mobile Network

The brand-new PW MOBILE 4G 2.0 allows to install dispenser wherever desired, even in the most remote area, without the need of a local network: the device uses the mobile 4G technology to communicate and transfer data.





NOZZLES



FILTRATION



TANK MONITORING



HOSE REEL



ACCESSORIES



MERCHANDISE

INDEX



AIR



ANTIFREEZE



AdBlue®



BIODIESEL



DIESEL



FOOD



GASOLINE



GREASE



KEROSENE



OIL



WATER



WINDSCREEN

PW MOBILE



A new communication system that allows you to transfer data using mobile 4G network.

KEY READER & MANAGER KEY 2.0



LAN



A network card that allows the RS485 signal to be converted for connection to a LAN, through a simple and intuitive interface.

PW WI-FI



A device that allows to convert the RS485 signal to Wi-Fi, through a simple and intuitive interface.

TECHNICAL DATA

CODE	DESCRIPTION
F1271012A	PW WIFI 2.0
F12710130	PW MOBILE 4G 2.0
F20552010	MANAGER KEY 2.0
F1226201A	KIT KEY READER



CAR FILLING



FUEL MANAGEMENT SYSTEMS



KITS



PUMPS



METERS



METERED NOZZLES

SELF SERVICE MC 2.0

FEATURES

- STURDY STRUCTURE
- ALL-IN-ONE DISPENSER
- BUILT-IN LAN ADAPTER
- FRONT DOOR FOR EASY MAINTENANCE
- SSM 2.0 SOFTWARE REQUIRED
- IP55
- IDEAL FOR FUEL MANAGEMENT

The PIUSI SELF SERVICE MC 2.0 maintains all the advantages of the renown MC system integrated in an AdBlue® dispenser while granting all the 2.0 features: AdBlue® consumption monitoring and report, fleet management, vehicles and users control.

PERFORMANCE

UP TO

32 L/MIN

FLOW RATE

LAN

CONNECTION

±1%

ACCURACY



SELF SERVICE MC 2.0



PACKAGING

CODE	WEIGHT		PACKAGING		N. BOXES/EUROPALLET	
	KG	LBS	MM	PCS/BOX		
FO074306A	50	110	1478X488X400	1	6*	4



NOZZLES



FILTRATION



TANK MONITORING



HOSE REEL



ACCESSORIES



MERCHANDISE

INDEX



AIR



ANTIFREEZE



AdBlue®



BIODIESEL



DIESEL



FOOD



GASOLINE



GREASE



KEROSENE



OIL



WATER



WINDSCREEN

CHART

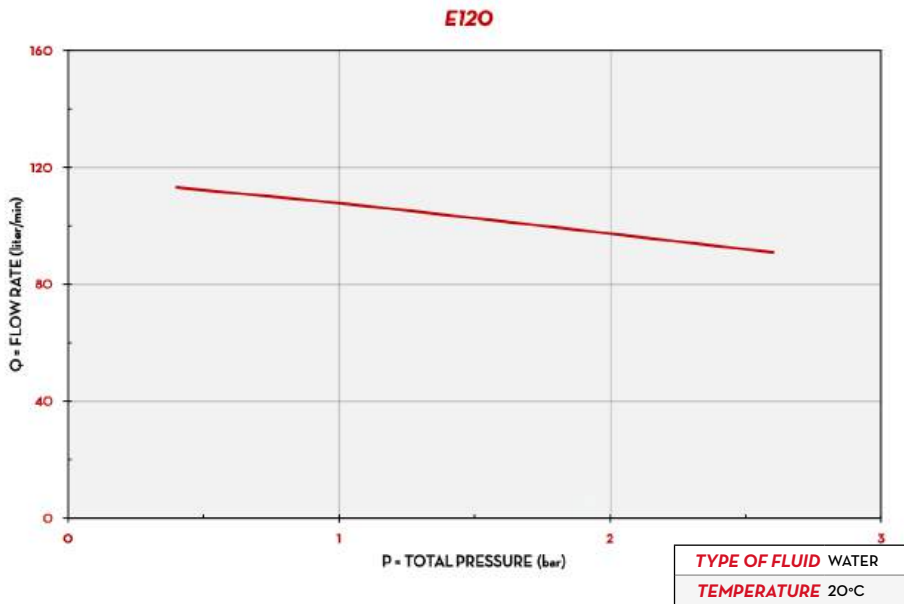

DIMENSIONS

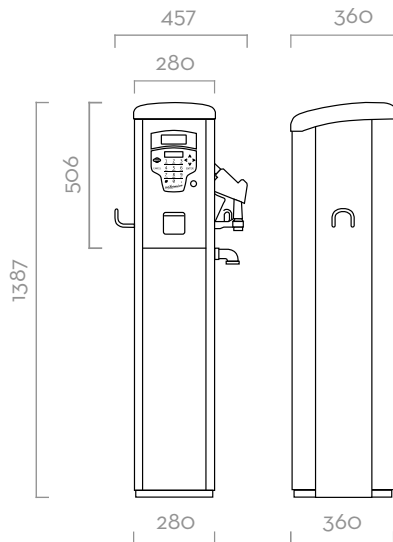

Dimensions expressed in millimeters

IN THE BOX

- SELF SERVICE MC 2.0 DISPENSER
- DELIVERY HOSE
- SB325_X NOZZLE
- INSTRUCTION MANUAL

DETAILS



SSM 2.0 SOFTWARE (PAG. 34)

COMPONENTS

- **PUMP:**
SUZZARABLU PUMP AC
- **METER:**
K24
- **NOZZLE:**
SB325_X
- **FILTER:**
3D FILTER

TECHNICAL DATA

CODE	DESCRIPTION	FLUIDS TYPE	FLOW RATE		VOLTAGE			METER	NOZZLE	FILTER	INLET	DELIVERY HOSE	
			L/MIN	GPM	AC V/HZ	DC VOLT	POWER WATT	AMP. MAX.	MOD.	TYPE	3D FILTER	BSP	LENGHT
FO074306A	SELF SERVICE 70 MC 2.0 FOR ADBLUE		32	8,5	230/50		400	1,95	K24	SB325	YES	3/4"	6 M



CAR FILLING



FUEL MANAGEMENT SYSTEMS



KITS



PUMPS



METERS



METERED NOZZLES

MCBOX 2.0

FEATURES

- FLEET MANAGEMENT
- SUITABLE FOR ANY PUMP
- PULSE METER INPUT
- LAN/WI-FI VERSION AVAILABLE
- SSM2.0 SOFTWARE REQUIRED

The PIUSI MCBOX 2.0 is the evolution of the MCBOX system thanks to the integration with the 2.0 features: AdBlue® consumption monitoring and report, fleet management, vehicles and users control. It is suitable to manage and control an existing pump, pulse meter and nozzle.

PERFORMANCE

UP TO
1000
USERS / VEHICLES

AC
VOLTAGE
POWER



MCBOX 2.0



PACKAGING

CODE	WEIGHT		PACKAGING		
	KG	LBS	MM	INCH	PCS/BOX
FO059701A	9	19,4	480X370X265	18,9X14,6X10,4	1
FO059702A	5	19,4	480X370X265	18,9X14,6X10,4	1



NOZZLES



FILTRATION



TANK MONITORING



HOSE REEL



ACCESSORIES



MERCHANDISE

INDEX



AIR



ANTIFREEZE



AdBlue®



BIODIESEL



DIESEL



FOOD



GASOLINE



GREASE



KEROSENE



OIL



WATER



WINDSCREEN

CONNECTION SCHEME

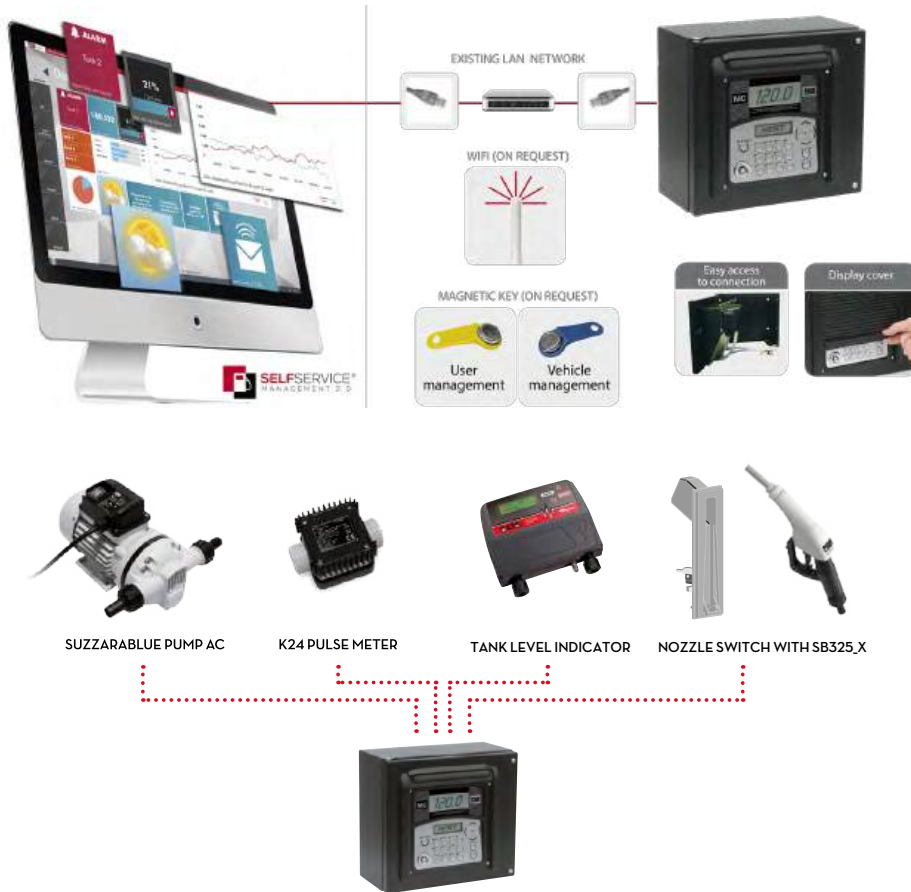

IN THE BOX

- MCBOX 2.0 UNIT
- LAN/WI-FI ADAPTER
- INSTRUCTION MANUAL

DETAILS



SHUTTER



USER / VEHICLE KEY



SSM 2.0 SOFTWARE (PAG. 34)



EASY ACCESS TO CONNECTION

DIMENSIONS

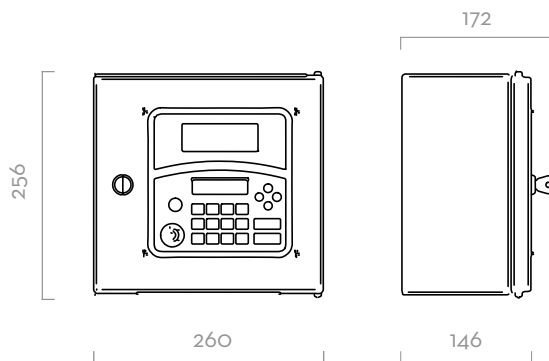

Dimensions expressed in millimeters

TECHNICAL DATA

CODICE	DESCRIZIONE	TIPO LIQUIDI	TENSIONE			SOFTWARE SELF SERVICE MANAGEMENT 2.0
			CA V/Hz	POTENZA W	A MAX (load motor)	
FO059701A	MCBOX LAN 2.0		90-240V - 50/60Hz	35	6,5	REQUIRED
FO059702A	MCBOX WIFI 2.0		90-240V - 50/60Hz	35	6,5	REQUIRED



CAR FILLING



FUEL MANAGEMENT SYSTEMS



KITS



PUMPS



METERS



METERED NOZZLES

SSM AGILIS

FEATURES

- VIRTUAL TANK MONITORING
- EASY INSTALLATION
- REPORT TRANSACTION
- CUSTOMIZABLE EXPORTS

AGILIS products can be used on their own, but with the SSM AGILIS software they become true allies of the company owner.

This software is constantly being developed and updated by PIUSI, so much so that it is the benchmark for all entry-level fuel management systems to easily, and comprehensively, monitor dispensing in every company vehicle.

AGILIS IS THE IDEAL SYSTEM FOR SMALL & MEDIUM ENTERPRISES

PERFORMANCE

UP TO

16

DISPENSERS

USB/WEB
SOFTWARE VERSION

INSTALLATION

SOFTWARE ACTIVATION MODE



**USB
HARDWARE KEY**
without internet
connection



**WEB
EDITION**
internet connection
required





NOZZLES



FILTRATION



TANK MONITORING



HOSE REEL



ACCESSORIES



MERCHANDISE

INDEX

AIR ANTIFREEZE AdBlue® BIODIESEL DIESEL FOOD GASOLINE GREASE KEROSENE OIL WATER WINDSCREEN

An effective system for small and medium enterprises that use their own tanks for refuelling their work vehicles with diesel

- Offers a wide range of solutions in terms of applications, dispenser type and voltage
- Authorises access to fuel simply and automatically, by means of a PIN or yellow key
- Manages up to 250 users per dispenser
- Monitors tank level (virtual tanks only)
- Records all dispensing data
- Easy to connect to your computer in the way that suits you best: PW14, PW Mobile, PW Lan, PW Wifi, Manager Key
- Exports full, custom reports
- Works both with and without dedicated software

BENEFITS



Prevents losses and unauthorised withdrawals



Prevents machine downtimes caused by fuel shortages



Optimises reporting, thereby freeing up company resources



Provides long service-life due to its rugged construction, high quality and ease of use

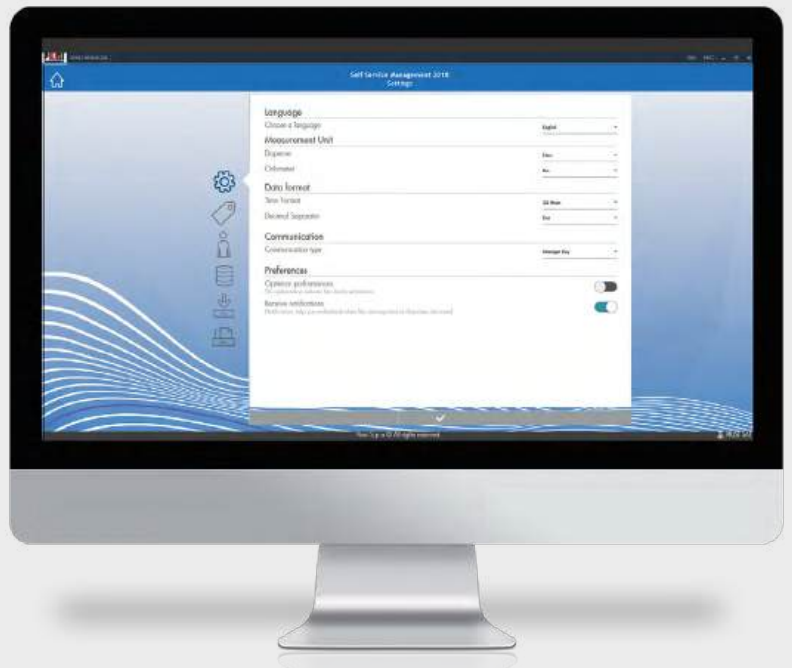

TECHNICAL DATA

CODE	DESCRIPTION
FO0773050	SELF SERVICE MANAGEMENT AGILIS - USB
FO0773250	SELF SERVICE MANAGEMENT AGILIS - WEB



CAR FILLING



FUEL MANAGEMENT SYSTEMS



KITS



PUMPS



METERS



METERED NOZZLES

DATA TRANSFER AGILIS

DATA TRANSFER SSM AGILIS is a set of different solutions that let to download the transactions from the dispensers to the SELF SERVICE MANAGEMENT AGILIS software. The great variety of the offer is based on the technology required.

Manual download

The easiest way to download the informations is through the Manager key, it is enough to touch the dispenser with the key to transfer all the transactions and download them on the software.

Local network

Use the local network Lan/Wi-Fi to download the dispenser to your pc. By choosing between the PWLAN or PW Wi-Fi it is possible to set up a connection that let you receive all the transactions in real time.

Mobile network

Thanks to the new PW MOBILE 4G is now possible to install all the dispensers everywhere in the world with just the need of a mobile network coverage, with SIM card, avoiding all the local network configurations.



PW14 / RS 485

MANAGER KEY

PW-LAN

PW-WIFI

PW-MOBILE





NOZZLES



FILTRATION



TANK MONITORING



HOSE REEL



ACCESSORIES



MERCHANDISE

INDEX

PW14 / RS 485



Connection via RS485 cable with USB converter.

KEY READER, MANAGER KEY & MANAGER KEY USB TYPE C



PW LAN



A device that allows to convert the RS485 signal to LAN, through a simple and intuitive interface.



A device that allows to convert the RS485 signal to Wi-Fi, through a simple and intuitive interface.



A new omuncation system that allows you to transfer data using mobile 4G network.

TECHNICAL DATA

CODE	DESCRIPTION
F13292000	PW14 - USB CONVERTER
F1226201A	KIT KEY READER
F23525000	MANAGER KEY USB TYPE C
F1249600A	MANAGER KEY
F1271005A	PW-LAN
F1271004B	PW-WIFI
F1271015A	PW MOBILE 4G



CAR FILLING



FUEL MANAGEMENT SYSTEMS



KITS



PUMPS



METERS



METERED NOZZLES

CUBE ADBLUE AGILIS

FEATURES

- MULTI-USER MANAGEMENT
- 3D FILTER AVAILABLE
- COMPACT DESIGN
- COMPATIBLE WITH SSM AGILIS SOFTWARE
- IP55

CUBE ADBLUE AGILIS is a private dispenser designed to simplify the transfer, dispensing, and monitoring of AdBlue® safely and reliably. Compact and modern, it is equipped with a self-priming membrane pump with a flow rate of 30 l/min, ideal for quick and efficient use. The patented SB325_X automatic nozzle with break-away system ensures safety and precision, while the specific 3D filter guarantees impurity-free dispensing. The 6-meter delivery hose provides great operational flexibility, and the integrated microswitch automatically turns off the pump when the nozzle is placed back, ensuring convenience and safety.

PERFORMANCE

UP TO 30 L/MIN	UP TO 250
FLOW RATE	USERS
±1%	AC
ACCURACY	VOLTAGE



CUBE ADBLUE AGILIS



PACKAGING

CODE	WEIGHT		PACKAGING		N. BOXES/EUROPALLET	
	KG	LBS	MM	PCS/BOX		
FO0594A00	22	48,5	380X380X480	1	12	24



NOZZLES



FILTRATION



TANK MONITORING



HOSE REEL



ACCESSORIES



MERCHANDISE

INDEX



AIR



ANTIFREEZE



AdBlue®



BIODIESEL



DIESEL



FOOD



GASOLINE



GREASE



KEROSENE



OIL



WATER



WINDSCREEN

DIMENSIONS

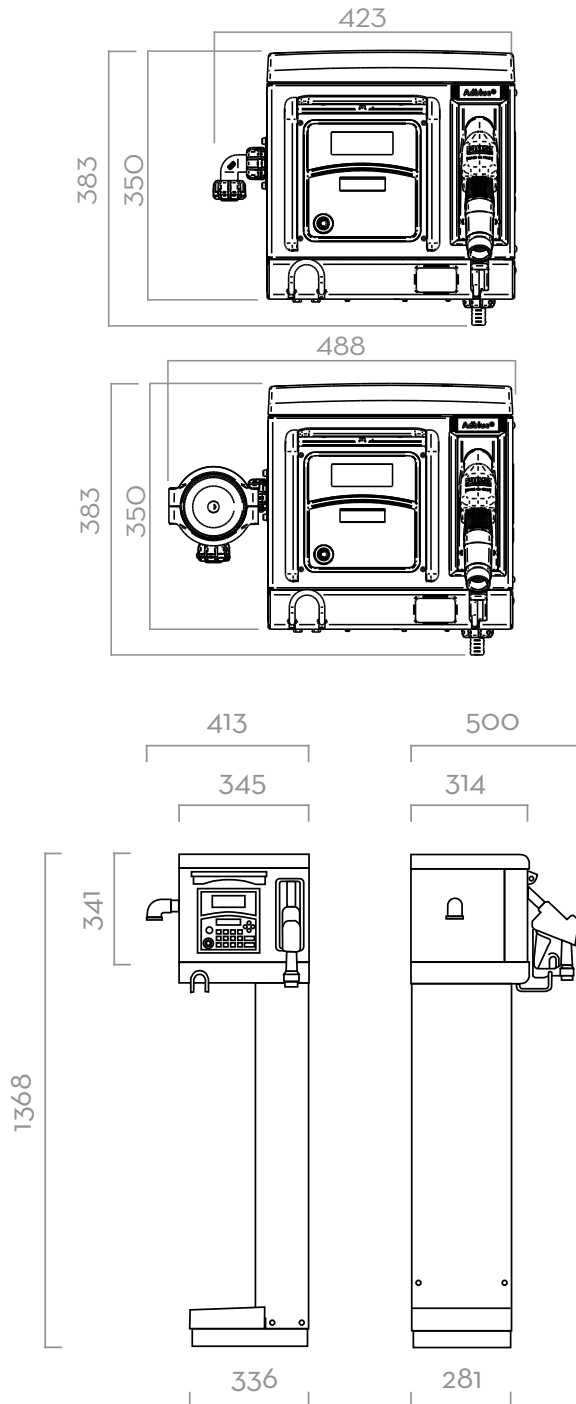

Dimensions expressed in millimeters

IN THE BOX

- DISPENSER CUBE MC ADBLUE
- 3D FILTER
- DELIVERY HOSE
- AUTOMATIC NOZZLE SB325_X

DETAILS

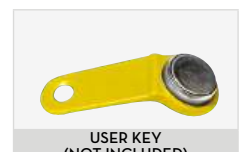

COMPONENTS

- **PUMP:**
SUZZARABLUE PUMP AC
- **METER:**
K24 PULSER
- **NOZZLE:**
SB325_X
- **FILTER:**
3D FILTER

TECHNICAL DATA

CODE	DESCRIPTION	FLUIDS TYPE	FLOW RATE		VOLTAGE			PUMP	METER	NOZZLE	INLET	DELIVERY HOSE	
			L/MIN	GPM	AC V/HZ DC VOLT	POWER WATT	AMP. MAX.					TYPE	LENGTH
FO074400B	CUBE ADBLUE MC 230V/50HZ 250U AGILIS	Ad W	30	7,9	230/50	400	1,95	SUZZARABLUE PUMP	K24 PULSER	SB325_X	3/4"	6 M	3,4"



CAR FILLING



FUEL MANAGEMENT SYSTEMS



KITS



PUMPS



METERS



METERED NOZZLES

SELF SERVICE MC

FEATURES

- CONTROLLED ACCESS
- BUILT-IN FILTER
- ALL-IN-ONE EQUIPMENT
- COMPACT DESIGN
- SSM AGILIS SOFTWARE ON REQUEST

The PIUSI SELF SERVICE MC is the combination of the PIUSI MC technology and the Suzzarablue product range. This AdBlue® dispenser is composed of the MC panel, the SUZZARABLUE PUMP, the SB325_X nozzle, the K24 pulse meter and 3D FILTER.

PERFORMANCE

UP TO 32 L/MIN	UP TO 250
FLOW RATE	USERS
±1%	
ACCURACY	



SELF SERVICE MC

PACKAGING

CODE	WEIGHT		PACKAGING		N. BOXES/EUROPALLET	
	KG	LBS	MM	PCS/BOX		
FO074400B	50	110	1478X488X400	1	6	4



NOZZLES



FILTRATION



TANK MONITORING



HOSE REEL



ACCESSORIES



MERCHANDISE

INDEX



AIR



ANTIFREEZE



AdBlue®



BIODIESEL



DIESEL



FOOD



GASOLINE



GREASE



KEROSENE



OIL



WATER



WINDSCREEN

CHART

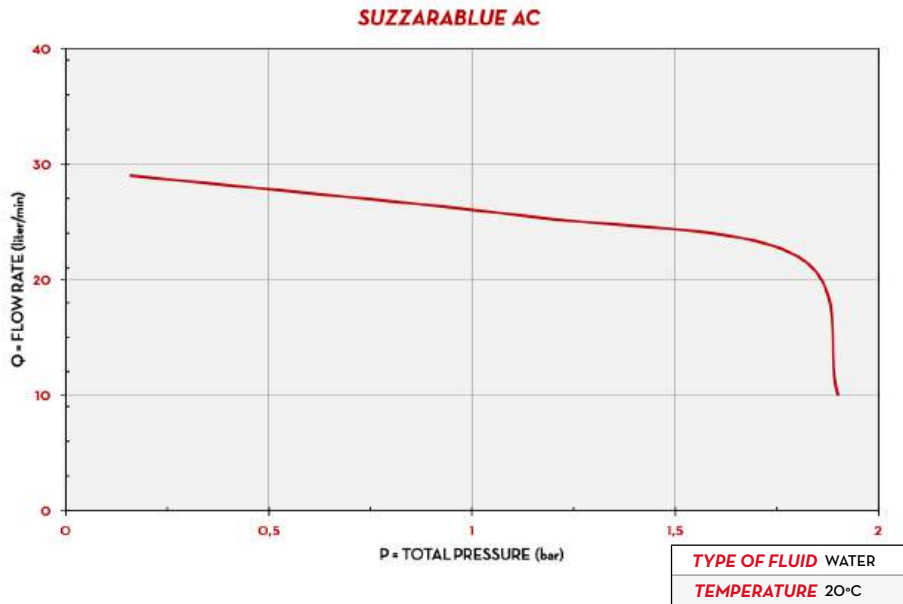

DIMENSIONS

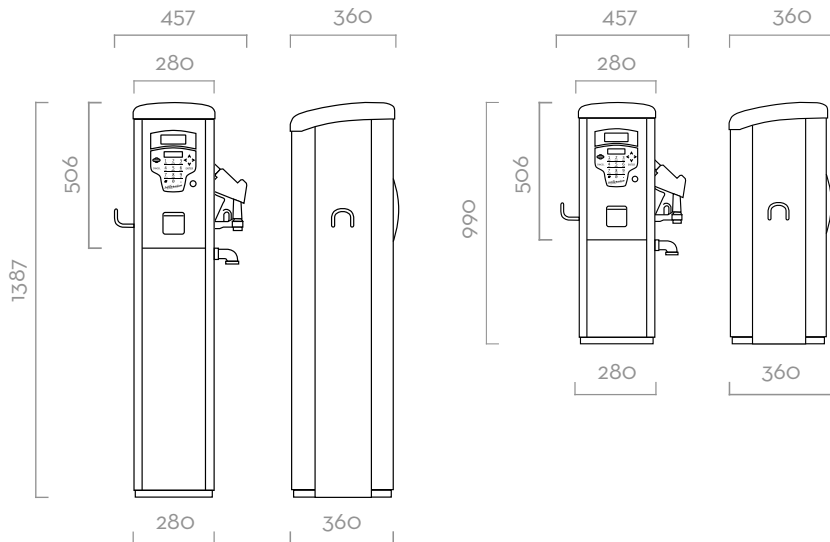

Dimensions expressed in millimeters

IN THE BOX

- SELF SERVICE MC DISPENSER
- DELIVERY HOSE
- SB325_X NOZZLE
- INSTRUCTION MANUAL

DETAILS



COMPONENTS

- **PUMP:**
SUZZARABLUE PUMP AC
- **METER:**
K24
- **NOZZLE:**
SB325_X
- **FILTER:**
3D FILTER

TECHNICAL DATA

CODE	DESCRIPTION	FLUIDS TYPE	FLOW RATE		VOLTAGE			METER	NOZZLE	FILTER	INLET	DELIVERY HOSE
			L/MIN	GPM	AC V/HZ	DC VOLT	POWER WATT					
FO074400B	SELFSEV.MC ADBL 230V/50HZ AGILIS		32	8,5	230/50	400	1,95	K24	SB325	YES	3/4"	6 M



CAR FILLING



FUEL MANAGEMENT SYSTEMS



KITS



PUMPS



METERS



METERED NOZZLES

MCBOX

FEATURES

- ACCESS CONTROL
- SUITABLE FOR ANY PUMP
- PULSE METER INPUT
- EASY TO INSTALL
- MULTI USERS
- COMPATIBLE WITH SSM AGILIS SOFTWARE
- AVAILABLE IN COMPACT VERSION

PIUSI MCBOX is a multi-user control panel that manages the pump, authorized access, preset dispensing, and pulse meter. Integrated with SELF SERVICE MANAGEMENT AGILIS, it allows downloading of all transactions. Also available in a compact version for installations in confined spaces.

PERFORMANCE

UP TO
250

USERS

AC
VOLTAGE

POWER



MCBOX



MCBOX COMPATTO



PACKAGING

CODE	WEIGHT		PACKAGING		N. BOXES/EUROPALLET	
	KG	LBS	MM	PCS/BOX		
F13980COO	2,3	5	260X240X170	1	-	-
F13980O6C	5	19,4	480X370X265	1	-	-



NOZZLES



FILTRATION



TANK MONITORING



HOSE REEL



ACCESSORIES



MERCHANDISE

INDEX



AIR



ANTIFREEZE



AdBlue®



BIODIESEL



DIESEL



FOOD



GASOLINE



GREASE



KEROSENE



OIL



WATER



WINDSCREEN

CONNECTION SCHEME

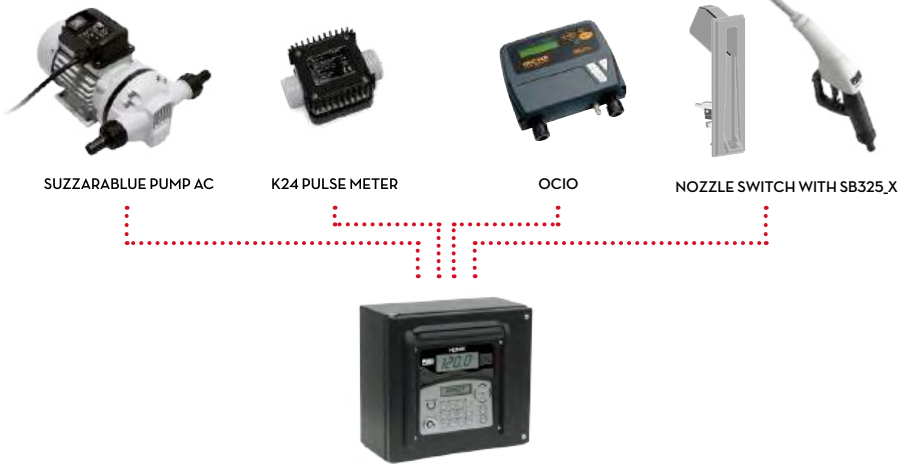

IN THE BOX

- MCBOX UNIT OR MCBOX COMPACT
- INSTRUCTION MANUAL

DETAILS



SHUTTER



SSM AGILIS SOFTWARE



EASY ACCESS TO CONNECTION



USER KEY

DIMENSIONS

MCBOX

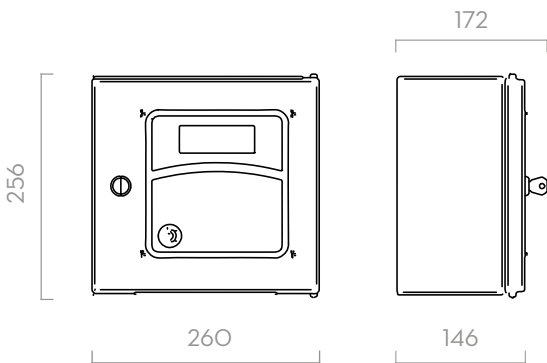

MCBOX COMPACT

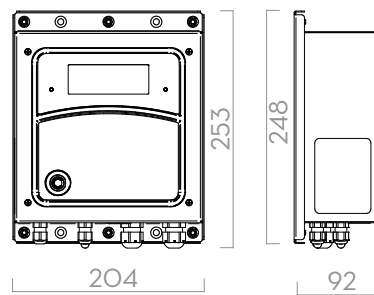

Dimensions expressed in millimeters

TECHNICAL DATA

CODE	DESCRIPTION	FLUIDS TYPE	USERS	VOLTAGE			METERS
				HZ	POWER WATT	AMP. MAX. (load motor)	
F1398OC00	MCBOX 100-240V AGILIS C 80 UTENTI - COMPACT		80	50/60 Hz	100-240V	15 A	-
F1398006C	MCBOX 100-240V 250U UREA AGILIS		250	50/60 Hz	100-240V	15	-



FUEL MANAGEMENT SYSTEMS

ACCESSORIES

B.SMART

SELF SERVICE B.SMART	CODE	DESCRIPTION	
	F22500000	DRIVER ACCESS (X10)	 F1590400A F00770D00 F00770D10 F00770D20
	FO0770D20	DRIVER ACCESS (X50)	
	F1590400A	USER KEY (YELLOW KEY: 10PCS)	

MCBOX B.SMART	CODE	DESCRIPTION	
	F1270800C	KIT PEDESTAL CUBE BLACK	 F1590400A F1270800C F1273700A F00770D00 F00770D10 F00770D20
	F22500000	DRIVER ACCESS (X10)	
	FO0770D20	DRIVER ACCESS (X50)	
	F1590400A	USER KEY (YELLOW KEY: 10PCS)	
	F1273700A	KIT HANG WALL	

SSM2.0

SELF SERVICE MC 2.0	CODE	DESCRIPTION	
	F1590400A	KIT DRIVER KEY YELLOW (10PCS)	 F1590400A F17299000
	F17299000	KIT VEHICLE KEY BLUE (10PCS)	

MCBOX 2.0	CODE	DESCRIPTION	
	F1590400A	KIT DRIVER KEY YELLOW (10PCS)	 F1590400A F17299000
	F17299000	KIT VEHICLE KEY BLUE (10PCS)	

SSM AGILIS

SELF SERVICE MC	CODE	DESCRIPTION	
	F1590400A	KIT DRIVER KEY YELLOW (10PCS)	 F1590400A F1249600A
	F1249600A	MANAGER KEY	

MCBOX	CODE	DESCRIPTION	
	F1270800C	KIT PEDESTAL CUBE BLACK	 F1270800C F1590400A F1249600A F1623900B
	F1590400A	KIT DRIVER KEY YELLOW (10PCS)	
	F17121000	LEVEL PROBE FOR ACCESS 85	
	F1249600A	MANAGER KEY	
	F1623900B	NOZZLE HOLDER SS+CABLED SWITCH FM/MC	





KITS





CAR FILLING



FUEL MANAGEMENT SYSTEMS



KITS



PUMPS



METERS



METERED NOZZLES

SUZZARABLUE DRUM

FEATURES

- DESIGNED FOR 200 L DRUM
- EASY TO INSTALL
- SUZZARABLUE PUMP

The PIUSI SUZZARABLUE DRUM is the solution for all the AdBlue® drum applications. Its adjustable bracket allows an easy installation on any kind of barrel.

PERFORMANCE

UP TO

32 L/MIN

FLOW RATE

AC
VOLTAGE

POWER

20 MIN

DUTY CYCLE



SUZZARABLUE DRUM

PACKAGING

CODE	WEIGHT		PACKAGING		
	KG	LBS	MM	INCH	PCS/BOX
FOO20135E	16	35,3	470X370X265	18,3X14,6X10,4	1
FOO201D5C	16	35,3	470X370X265	18,3X14,6X10,4	1
FOO201E5C	16	35,3	470X370X265	18,3X14,6X10,4	1



NOZZLES



FILTRATION



TANK MONITORING



HOSE REEL



ACCESSORIES



MERCHANDISE

INDEX



AIR



ANTIFREEZE



AdBlue®



BIODIESEL



DIESEL



FOOD



GASOLINE



GREASE



KEROSENE



OIL



WATER



WINDSCREEN

CHART

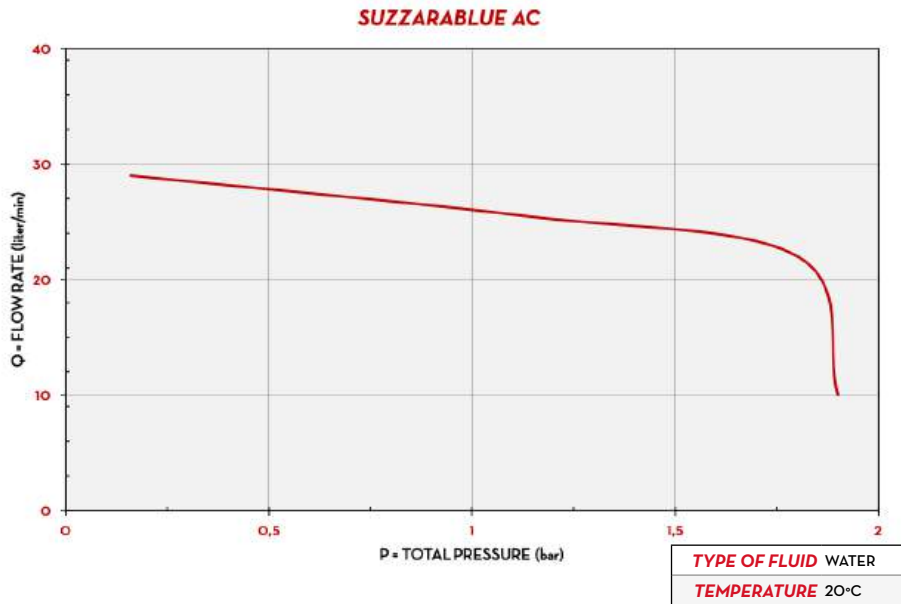

DIMENSIONS

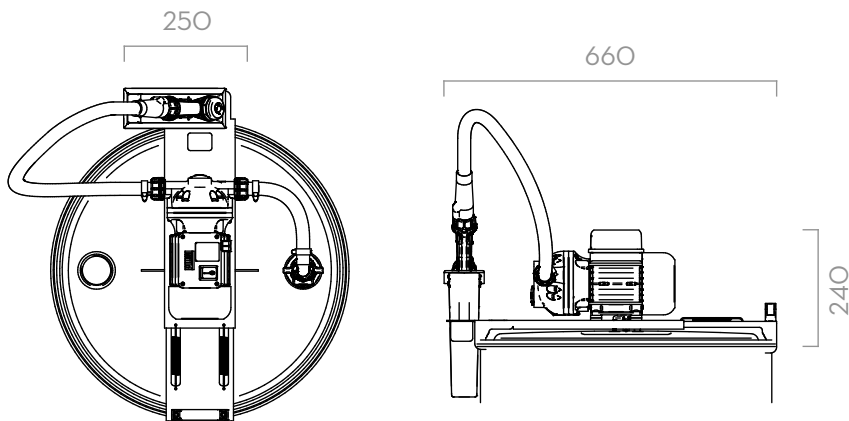

Dimensions expressed in millimeters

IN THE BOX

- SUZZARABLU DRUM UNIT
- SB325_X / SB325_X METER NOZZLE (ON REQUEST)
- AF2 CONNECTOR
- SUCTION PIPE
- DELIVERY HOSE
- INSTRUCTION MANUAL

DETAILS



SUZZARABLU PUMP AC



AF2 CONNECTOR



SUCTION PIPE

COMPONENTS

- **PUMP:**
SUZZARABLU PUMP AC
- **NOZZLE:**
SB325_X METER
SB325_X
SUZZARABLU MANUAL NOZZLE

TECHNICAL DATA

CODE	DESCRIPTION	FLUIDS TYPE	FLOW RATE		VOLTAGE			METER MOD.	NOZZLE TYPE	CONNECTOR	HOSE		ON/OFF SWITCH
			L/MIN	GPM	AC V./HZ DC VOLT	POWER WATT	AMP. MAX.				LENGHT	Ø	
FOO20135E	SUZZARABLU DRUM 230V/50HZ		32	8,5	230/50	400	1.95	NO	MAN.	AF2	6 M	3/4"	YES
FOO201D5C	SUZZARABLU DRUM 230V/50HZ - SB325_X		32	8,5	230/50	400	1.95	NO	SB325	AF2	6 M	3/4"	YES
FOO201E5C	SUZZARABLU DRUM 230V/50HZ - SB325_X MET		32	8,5	230/50	400	1.95	SB325_X	SB325_X	AF2	6 M	3/4"	YES



CAR FILLING



FUEL MANAGEMENT SYSTEMS



KITS



PUMPS



METERS



METERED NOZZLES

SUZZARABLUE 3 PRO

FEATURES

- **STURDY DESIGN**
- **RELIABILITY AND PERFORMANCE EVEN IN SUB-OPTIMAL SITUATIONS**
- **DISPENSIGN ALWAYS GUARANTEED**
- **ADBLUE® IS NEVER CONTAMINATED**
- **PERFECT FOR ALL CONDITION AND APPLICATIONS**
- **ERGONOMIC CONNECTION TO IBC**
- **WIDE RANGE OF CONFIGURATION POSSIBILITIES**
- **PIUSI METER (SB325_X METER OR K24)**

PERFORMANCE

UP TO 35 L/MIN	AC/DC VOLTAGE
FLOW RATE	POWER
6M	20 MIN
DELIVERY HOSE	DUTY CYCLE

SUZZARABLUE 3 PRO is the top of the PIUSI range for the transfer of AdBlue® from an IBC tank. Suitable for all working conditions and all commercial vehicles, it adds to the technical and performance characteristics of the SUZZARABLUE 3 BASIC version the precision of the K24 meter for AdBlue® or the SB325_X METER metered nozzle for precise dispensing.



SUZZARABLUE 3 PRO



PACKAGING

CODE	WEIGHT		PACKAGING		
	KG	LBS	MM	INCH	PCS/BOX
FO0101580	14,5	32	480X390X310	19,3X15,4X12,2	1
FO0101440	14,5	32	480X390X310	19,3X15,4X12,2	1
FO0101420	14,5	32	480X390X310	19,3X15,4X12,2	1
FO0101430	14,5	32	480X390X310	19,3X15,4X12,2	1
FO010102A	14,5	32	480X390X310	19,3X15,4X12,2	1
FO010100A	14,5	32	480X390X310	19,3X15,4X12,2	1



NOZZLES



FILTRATION



TANK MONITORING



HOSE REEL



ACCESSORIES



MERCHANDISE

INDEX



AIR



ANTIFREEZE



AdBlue®



BIODIESEL



DIESEL



FOOD



GASOLINE



GREASE



KEROSENE



OIL



WATER



WINDSCREEN

CHART

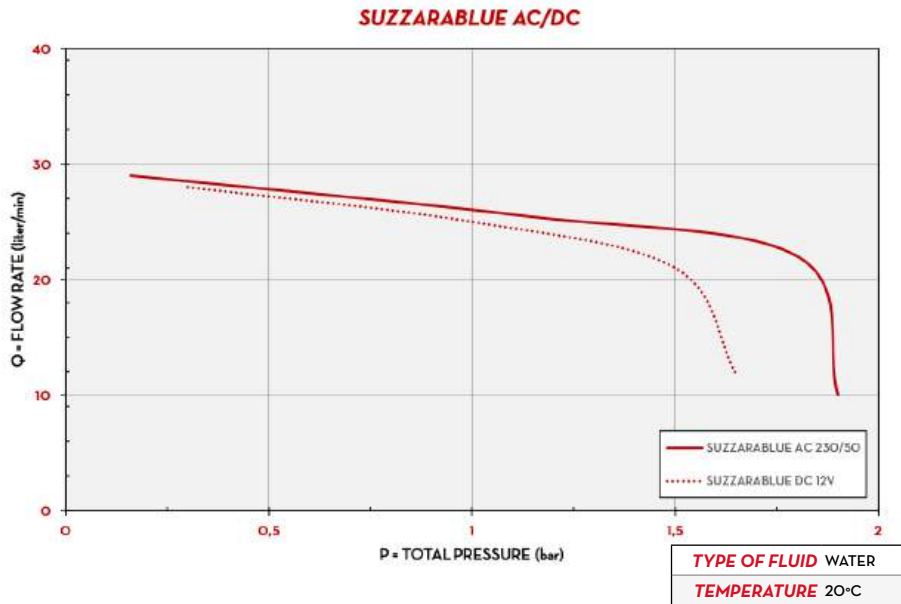

DIMENSIONS

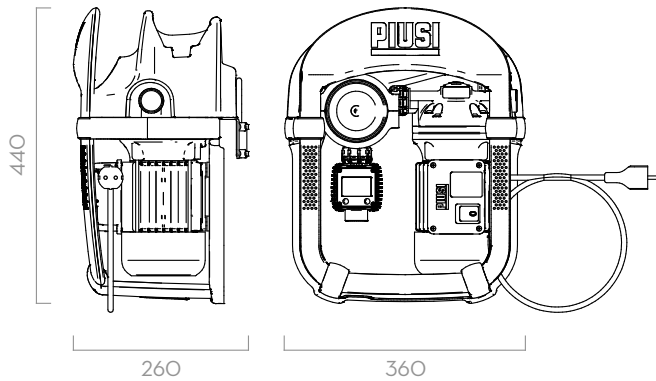

Dimensions expressed in millimeters

IN THE BOX

- SUZZARABLU 3 UNIT
- SUCTION & DELIVERY HOSE
- MANUAL/AUTOMATIC NOZZLE
- K24 METER (ON SELECTED VERSION)
- SEC CONNECTOR (*)
- 3D FILTER (ON SELECTED VERSION)
- INSTRUCTION MANUAL

DETAILS



COMPONENTS

- **PUMPS:**
SUZZARABLU PUMP AC
SUZZARABLU PUMP DC
- **NOZZLE:**
SB325_X
SUZZARABLU A60
SUZZARABLU MANUAL NOZZLE
- **FILTER:**
3D FILTER
- **METER:**
K24
SB325_X METER

TECHNICAL DATA

CODE	DESCRIPTION	FLUIDS TYPE	FLOW RATE		VOLTAGE	METER	NOZZLE	3D FILTER	IBC CONNECTOR	HOSE	
			L/MIN	GPM						SUCTION Ø 3/4	DELIVERY
FOO101580	SUZZ.BLUE3 PRO 230V/50 K24/MAN/EXT	Ad W	35	9,3	230V 50HZ	K24	MANUAL	NO	EXT	EXT	EXT
FOO101440	SUZZ.BLUE3 PRO 230V/50 K24/A60	Ad W	35	9,3	230V 50HZ	K24	A60	NO	SEC	1,5 M Ø20	6 M Ø20
FOO101420	SUZZ.BLUE3 PRO 230V/50 K24/SB325/EXT	Ad W	35	9,3	230V 50HZ	K24	SB325_X	NO	EXT	EXT	EXT
FOO101430	SUZZ.BLUE3 PRO 230V/50 K24/SB325	Ad W	35	9,3	230V 50HZ	K24	SB325_X	NO	SEC	1,5 M Ø20	6 M Ø20
FOO10102A	SUZZ.BLUE3 PURE PRO 230V/50 K24/SB325/EXT	Ad W	35	9,3	230V 50HZ	K24	SB325_X	YES	EXT	EXT	EXT
FOO10100A	SUZZ.BLUE3 PRO PURE 230V/50 K24/SB325	Ad W	35	9,3	230V 50HZ	K24	SB325_X	YES	SEC	1,5 M Ø20	6 M Ø20

*OTHER CONNECTORS AVAILABLE: AF2/EXTERNAL SUCTION

** OTHER NOZZLE AVAILABLE: SB325_X, SUZZARABLU A 60



CAR FILLING



FUEL MANAGEMENT SYSTEMS



KITS



PUMPS



METERS



METERED NOZZLES

SUZZARABLUE 3 BASIC

FEATURES

- **STURDY DESIGN**
- **RELIABILITY AND PERFORMANCE EVEN IN SUB-OPTIMAL SITUATIONS**
- **DISPENSIGN ALWAYS GUARANTEED**
- **ADBLUE® IS NEVER CONTAMINATED**
- **PERFECT FOR ALL CONDITION AND APPLICATIONS**
- **ERGONOMIC CONNECTION TO IBC**
- **WIDE RANGE OF CONFIGURATION POSSIBILITIES**

PIUSI SUZZARABLUE 3 BASIC, best seller in its range, is the PIUSI kit for IBC tanks specific for refilling AdBlue®. Suitable for all working conditions, SUZZARABLUE 3 BASIC is sturdy, reliable and safe over time. It is available in AC/DC version, it is equipped with the SUZZARABLUE PUMP, the 3D FILTER (in the PURE versions) and an automatic or manual nozzle.

PERFORMANCE

UP TO

35 L/MIN

FLOW RATE

AC/DC

VOLTAGE

POWER

6M

LENGTH

DELIVERY HOSE

20MIN

DUTY CYCLE



SUZZARABLUE 3 BASIC



PACKAGING

CODE	WEIGHT		PACKAGING		
	KG	LBS	MM	INCH	PCS/BOX
FO0101400	14,5	32	480X390X310	19,3X15,4X12,2	1
FO0101350	14,5	32	480X390X310	19,3X15,4X12,2	1
FO0101360	14,5	32	480X390X310	19,3X15,4X12,2	1
FO0101450	14,5	32	480X390X310	19,3X15,4X12,2	1
FO0101410	14,5	32	480X390X310	19,3X15,4X12,2	1



NOZZLES



FILTRATION



TANK MONITORING



HOSE REEL



ACCESSORIES



MERCHANDISE

INDEX



AIR



ANTIFREEZE



AdBlue®



BIODIESEL



DIESEL



FOOD



GASOLINE



GREASE



KEROSENE



OIL



WATER



WINDSCREEN

CHART

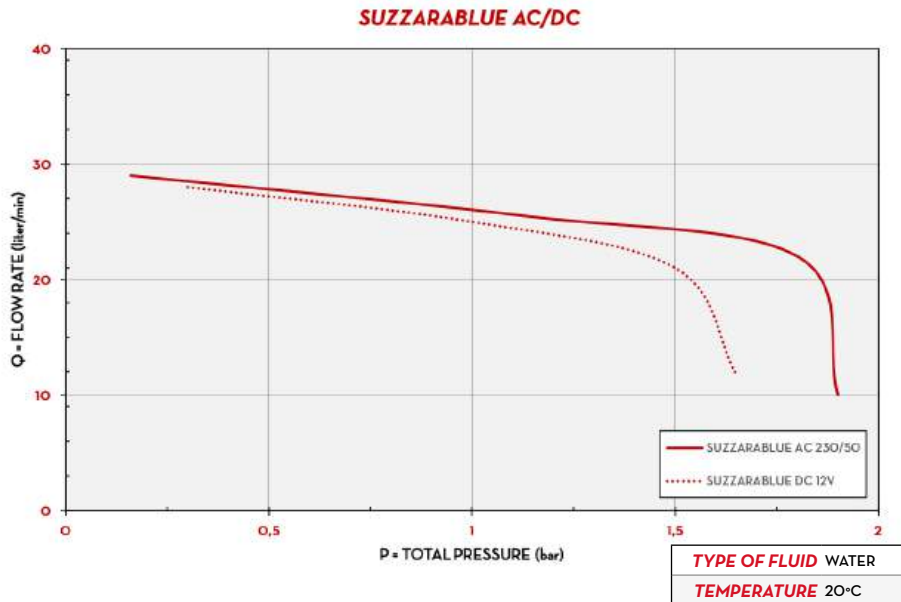

DIMENSIONS

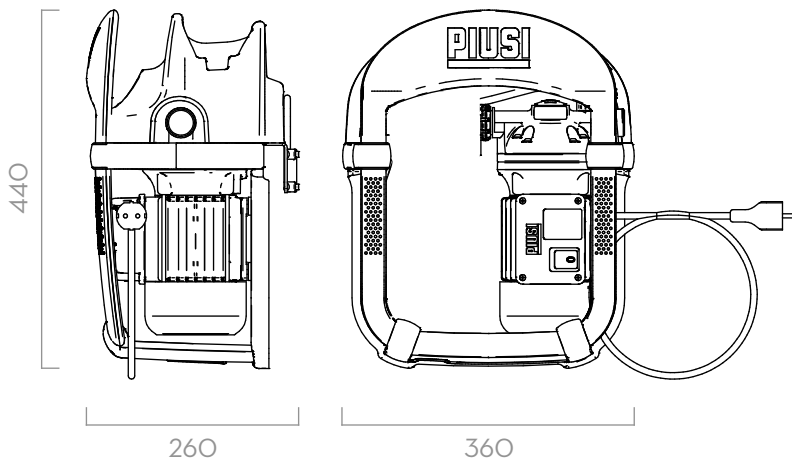

Dimensions expressed in millimeters

IN THE BOX

- SUZZARABLU 3 UNIT
- SUCTION & DELIVERY HOSE
- MANUAL/AUTOMATIC NOZZLE
- SEC CONNECTOR (*)
- 3D FILTER (ON SELECTED VERSION)
- INSTRUCTION MANUAL

DETAILS



SB325_X, MANUAL NOZZLE**



3D FILTER AVAILABLE

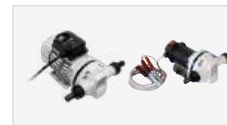

AC/DC PUMPS



SEC CONNECTOR AVAILABLE*

COMPONENTS

- PUMPS:
SUZZARABLU PUMP AC
SUZZARABLU PUMP DC
- NOZZLE:
SB325_X
SUZZARABLU A60
SUZZARABLU MANUAL NOZZLE
- FILTER:
3D FILTER

TECHNICAL DATA

CODE	DESCRIPTION	FLUIDS TYPE	FLOW RATE		VOLTAGE POWER	METER TYPE	NOZZLE TYPE	3D FILTER	IBC CONNECTOR	HOSE	
			L/MIN	GPM						SUCTION Ø 3/4	DELIVERY
FO0101400	SUZZ.BLUE3 BASIC 12V M.NOZ	(Ad) (W)	35	9,3	12V	NO	MANUAL	NO	SEC	1,5 M Ø20	6 M Ø20
FO0101350	SUZZ.BLUE3 BASIC 230V/50 W/A60	(Ad) (W)	35	9,3	230V 50HZ	NO	A60	NO	SEC	1,5 M Ø20	6 M Ø20
FO0101360	SUZZ.BLUE3 BASIC 230V/50 W/EXT	(Ad) (W)	35	9,3	230V 50HZ	NO	MANUAL	NO	EXT	EXT	EXT
FO0101450	SUZZ.BLUE3 BASIC 230V/50 M.NOZ	(Ad) (W)	35	9,3	230V 50HZ	NO	MANUAL	NO	SEC	1,5 M Ø20	6 M Ø20
FO0101410	SUZZ.BLUE3 BASIC 230V/50 SB325	(Ad) (W)	35	9,3	230V 50HZ	NO	SB325_X	NO	SEC	1,5 M Ø20	6 M Ø20

*OTHER CONNECTORS AVAILABLE: AF2/EXTERNAL SUCTION

** OTHER NOZZLE AVAILABLE: SUZZARABLU A 60



CAR FILLING



FUEL MANAGEMENT SYSTEMS



KITS



PUMPS



METERS



METERED NOZZLES

SUZZARABLUE PORTABLE KIT

FEATURES

- **READY TO USE**
- **TRANSPORTABLE**
- **CLAMPS FOR BATTERY CONNECTION**

Ease of use is the main feature of the PIUSI SUZZARABLUE PORTABLE KIT. The basic version of all Adblue® dispensers: it is composed by the SUZZARABLUE PUMP and SUZZARABLUE MANUAL NOZZLE.

PERFORMANCE

UP TO

35 L/MIN

FLOW RATE

AC/DC

VOLTAGE

POWER

20 MIN

DUTY CYCLE



SUZZARABLUE PORTABLE KIT



PACKAGING

CODE	WEIGHT		PACKAGING		N. BOXES / EUROPALLET	
	KG	LBS	MM	PCS/BOX		
FOO201AAA	8	17,6	357X327X275	1	24	36
FOO201C7A	10	22	357X327X275	1	24	36



NOZZLES



FILTRATION



TANK MONITORING



HOSE REEL



ACCESSORIES



MERCHANDISE

INDEX



AIR



ANTIFREEZE



AdBlue®



BIODIESEL



DIESEL



FOOD



GASOLINE



GREASE



KEROSENE



OIL



WATER



WINDSCREEN

CHART

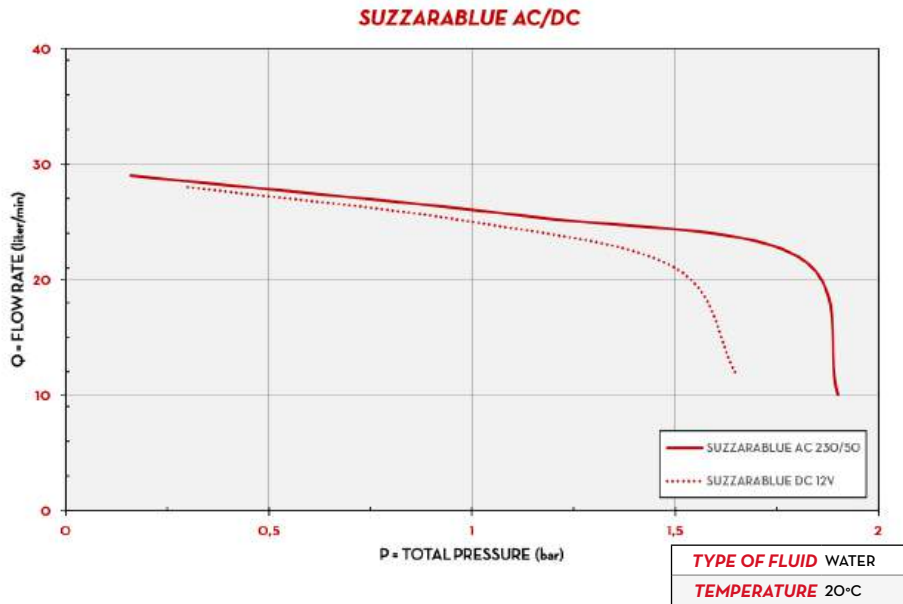

IN THE BOX

- SUZZARABLU PUMP AC/DC
- MANUAL NOZZLE
- FOOT VALVE
- SUCTION/DELIVERY HOSE
- INSTRUCTION MANUAL

DETAILS



MANUAL NOZZLE



FOOT VALVE



CLAMPS

DIMENSIONS

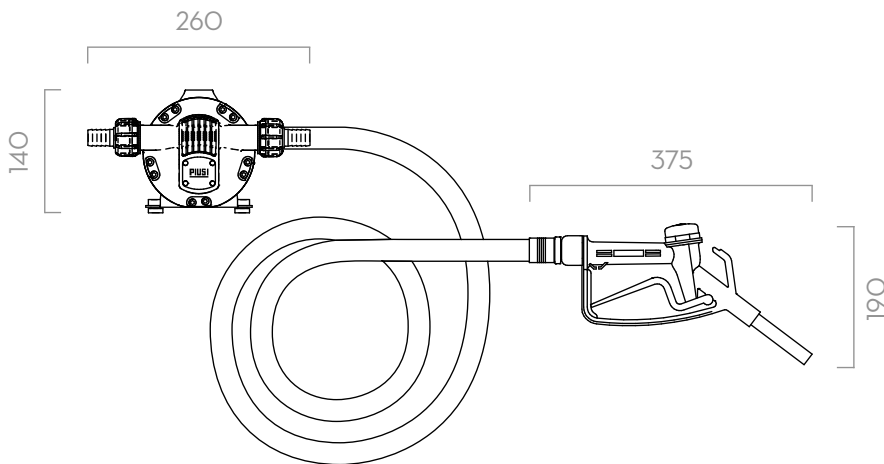

Dimensions expressed in millimeters

COMPONENTS

- **PUMP:**
SUZZARABLU PUMP AC
SUZZARABLU PUMP DC
- **NOZZLE:**
SUZZARABLU MANUAL NOZZLE

TECHNICAL DATA

CODE	DESCRIPTION	FLUIDS TYPE	FLOW RATE		VOLTAGE			NOZZLE TYPE	HOSE		ON/OFF SWITCH
			L/MIN	GPM	AC V/HZ DC VOLT	POWER WATT	AMP. MAX.		LENGHT	Ø	
FOO201AAA	SUZZARABLU KIT 12V		35	9,2	12	260	22	MANUAL	6 M	3/4"	YES
FOO201C7A	SUZZARABLU KIT 230 V		32	8,5	230/50	400	1,95	MANUAL	6 M	3/4"	YES



CAR FILLING



FUEL MANAGEMENT SYSTEMS



KITS



PUMPS



METERS



METERED NOZZLES

SUZZARABLUE BOX

FEATURES

- EASY TO INSTALL
- READY TO USE
- BUILT-IN LOCK

The PIUSI SUZZARABLUE BOX is specifically designed for wall or tank installation. Is is equipped with a metallic box which allows to lock up all the equipment.

PERFORMANCE

UP TO

32 L/MIN

FLOW RATE

AC
VOLTAGE
POWER

±1%

ACCURACY

20 MIN

DUTY CYCLE



SUZZARABLUE BOX



PACKAGING

CODE	WEIGHT		PACKAGING		
	KG	LBS	MM	INCH	PCS/BOX
FOO20196B	25	55,1	575X320X607	22,6X23,9	1



NOZZLES



FILTRATION



TANK MONITORING



HOSE REEL



ACCESSORIES



MERCHANDISE

INDEX



AIR



ANTIFREEZE



AdBlue®



BIODIESEL



DIESEL



FOOD



GASOLINE



GREASE



KEROSENE



OIL



WATER



WINDSCREEN

CHART

SUZZARABLU AC

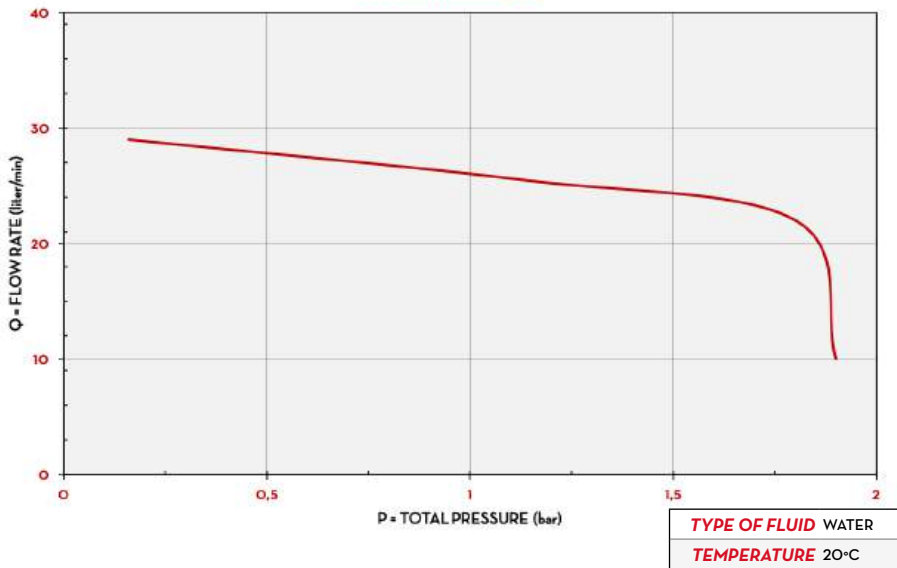

DIMENSIONS

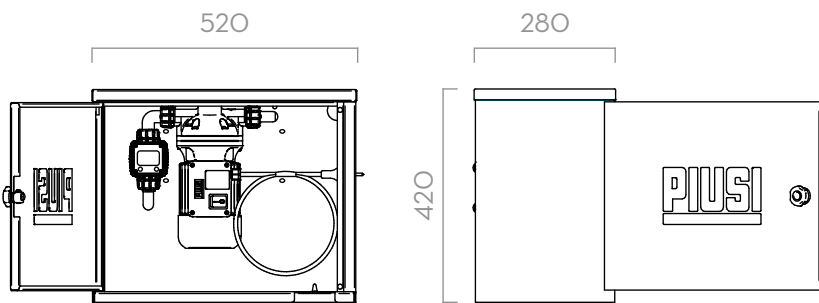

Dimensions expressed in millimeters

IN THE BOX

- SUZZARABLU PUMP AC
- K24 METER
- NOZZLE
- INSTRUCTION MANUAL

DETAILS



AUTOMATIC NOZZLE



FOOT VALVE



K24

COMPONENTS

- PUMP:
SUZZARABLU PUMP AC
- METER:
K24
- NOZZLE:
SUZZARABLU A60

TECHNICAL DATA

CODE	DESCRIPTION	FLUIDS TYPE	FLOW RATE		VOLTAGE			METER	NOZZLE	HOSE LENGTH
			L/MIN	GPM	AC V/HZ DC VOLT	POWER WATT	AMP. MAX.	MOD.	TYPE	
FOO20196B	SUZZARABLU BOX		32	8,5	230/50	400	1,95	K24	SUZZARABLU NOZZLE A60	6 M



KITS ACCESSORIES

DRUM





SUZZARABLU DRUM	CODE	DESCRIPTION
	F20189000	AF2 56X4 BUTTRESS - 1" BSP
	F20190000	AF2 2" BUTTRESS - 1" BSP
	F20257000	AF2 2" BSP - 1" BSP
	F20258000	AF2 2" 70X6 - 1" BSP





F20189000 / F20190000
F20257000 / F20258000

IBC

SUZZARABLU 3 PRO	CODE	DESCRIPTION
	F1206801B	SUZZARABLU CART KIT
	F15452000	SEC + HOSETAIL 90°
	F20189000	AF2 56X4 BUTTRESS / M 1" BSP
	F15515000	KIT BOTTOM CONNECTION W/FOOT VALVE 1.5MT
	F15606010	SUCTION DIP TUBE SUZZARABLU 2" BUTT
	F15606020	SUCTION DIP TUBE SUZZARABLU 2" BSP
	F15606000	SUCTION DIP TUBE SUZZARABLU 56X4
	F15515010	KIT BOTTOM CONNECTION W/FOOT VALVE 0.3MT
	F1917400A	KIT FOR SB325_X WITH MISF AND MAG AD
	FOO611D40	PIUSI 3D FILTER CARTRIDGE









F15452000 F1206801B F15606000 FOO611D40
F15606020 F15606010







F20189000 F15515000 F1917400A
F15515010

SUZZARABLU 3 BASIC	CODE	DESCRIPTION
	F1206801B	SUZZARABLU CART KIT
	F15452000	SEC + HOSETAIL 90°
	F20189000	AF2 56X4 BUTTRESS / M 1" BSP
	F15515000	KIT BOTTOM CONNECTION W/FOOT VALVE 1.5MT
	F15606010	SUCTION DIP TUBE SUZZARABLU 2" BUTT
	F15606020	SUCTION DIP TUBE SUZZARABLU 2" BSP
	F15606000	SUCTION DIP TUBE SUZZARABLU 56X4
	F15515010	KIT BOTTOM CONNECTION W/FOOT VALVE 0.3MT
	F1917400A	KIT FOR SB325_X WITH MISF AND MAG AD
	FOO611D40	PIUSI 3D FILTER CARTRIDGE









F15452000 F1206801B F15606000 FOO611D40
F15606020 F15606010

F20189000 F15515000 F1917400A
F15515010

ST

SUZZARABLU BOX	CODE	DESCRIPTION
	F1611800D	KIT COMPLETE BOX FOR SUZZARABLU BOX
	F20300000	PLATE SUZZ.BLU BOX - PEDESTAL CUBE
	F1270800C	KIT PEDESTAL CUBE BLACK

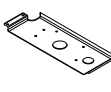
F1270800C F20300000 F1611800D





PUMPS

A solid red triangular shape is located in the bottom right corner of the page, pointing towards the top right.



CAR FILLING



FUEL MANAGEMENT SYSTEMS



KITS



PUMPS



METERS



METERED NOZZLES

SUZZARABLU PUMP AC

FEATURES

- **READY TO USE**
- **MULTI-PURPOSE PUMP**
- **SELF PRIMING**
- **BUILT-IN BYPASS VALVE**

The PIUSI SUZZARABLU PUMP AC is the most famous diaphragm pump for AdBlue®. It is equipped with electric motor without any dynamic seals. This solution allows to obtain a reliable industrial pump together with self priming capabilities.

PERFORMANCE

UP TO

32 L/MIN

FLOW RATE

20 MIN

DUTY CYCLE



SUZZARABLU PUMP AC



PACKAGING

CODE	WEIGHT		PACKAGING		N. BOXES/EUROPALLET	
	KG	LBS	MM	PCS/BOX		
FOO203090	7	15,4	350X180X280	1	60	84
FOO203200	7	15,4	350X180X280	1	60	84



NOZZLES



FILTRATION



TANK MONITORING



HOSE REEL



ACCESSORIES



MERCHANDISE

INDEX



AIR



ANTIFREEZE



AdBlue®



BIODIESEL



DIESEL



FOOD



GASOLINE



GREASE



KEROSENE



OIL



WATER



WINDSCREEN

CHART

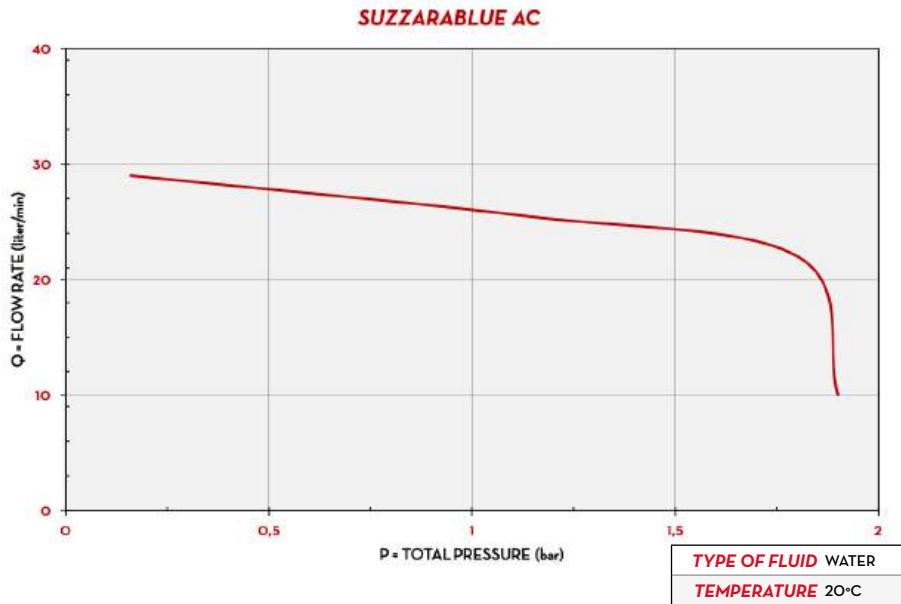

IN THE BOX

- SUZZARABLU PUMP AC
- HOSE FITTINGS
- INSTRUCTION MANUAL

DETAILS



DIMENSIONS

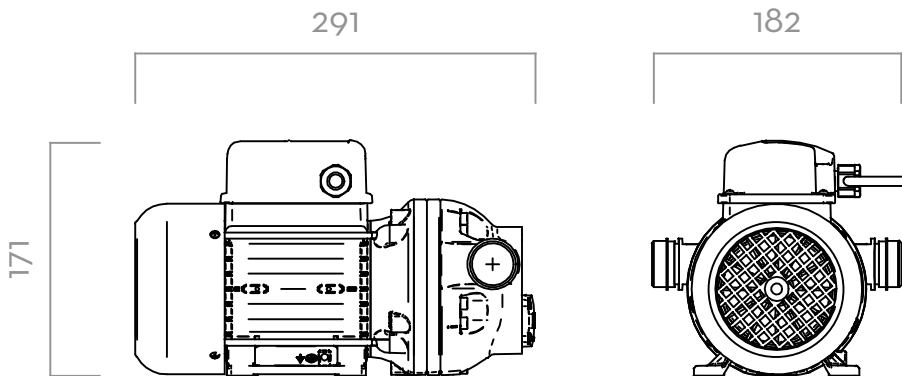

Dimensions expressed in millimeters

MATERIALS

- BODY: POLIPROPYLENE
- DIAPHRAGM: POLIPROPYLENE

TECHNICAL DATA

CODE	DESCRIPTION	FLUIDS TYPE	FLOW RATE		VOLTAGE			CABLES	INLET-OUTLET	ON/OFF	
			L/MIN	GPM	AC V/ HZ DC VOLT	RPM	POWER WATT				AMP. MAX.
FOO203090	SUZZARABLU AC PUMP 230/50		32	8,5	230/50	1450	400	1,95	YES	3/4"	YES
FOO203200	POMPA A MEMBRANA N 230/50HZ +CAVO+TIMER		32	8,5	230/50	1450	400	1,95	YES	3/4"	YES

UPON REQUEST IT IS AVAILABLE WITH DIFFERENT VOLTAGE AND FREQUENCY.



CAR FILLING



FUEL MANAGEMENT SYSTEMS



KITS



PUMPS



METERS



METERED NOZZLES

SUZZARABLUE PUMP DC

FEATURES

- **READY TO USE**
- **MULTI-PURPOSE PUMP**
- **SELF PRIMING**
- **BUILT-IN BYPASS VALVE**

The PIUSI SUZZARABLUE PUMP DC is an electric DC diaphragm pump suitable for transferring AdBlue®. This self-priming pump is equipped with a built-in pressure by-pass.

PERFORMANCE

UP TO

35 L/MIN

FLOW RATE

20 MIN

DUTY CYCLE



SUZZARABLUE PUMP DC



PACKAGING

CODE	WEIGHT		PACKAGING		N. BOXES/EUROPALLET	
	KG	LBS	MM	PCS/BOX		
FO0204080	3,6	7,9	350X180X280	1	60	84
FO0204090	3,6	7,9	350X180X280	1	60	84



NOZZLES



FILTRATION



TANK MONITORING



HOSE REEL



ACCESSORIES



MERCHANDISE

INDEX



AIR



ANTIFREEZE



AdBlue®



BIODIESEL



DIESEL



FOOD



GASOLINE



GREASE



KEROSENE



OIL



WATER



WINDSCREEN

CHART

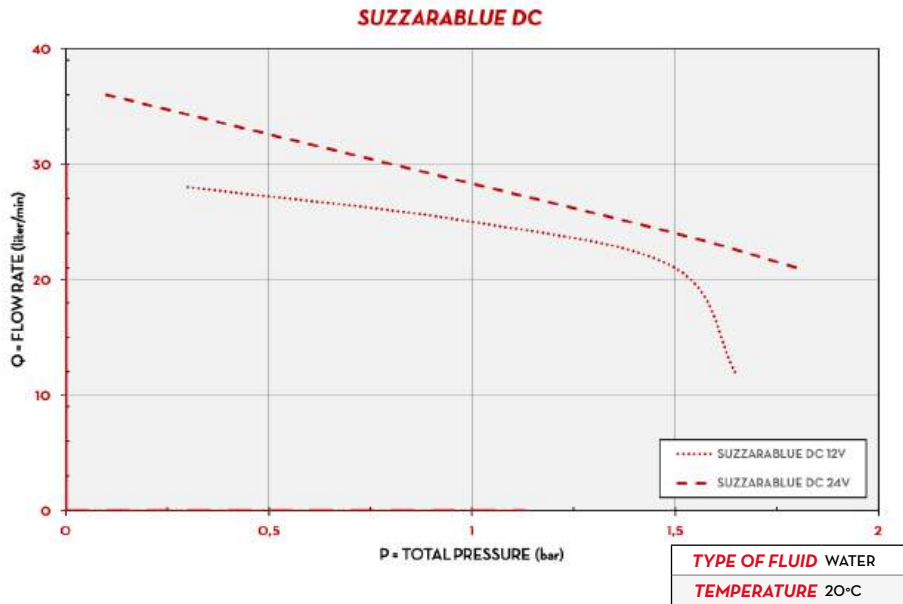

IN THE BOX

- SUZZARABLU PUMP DC
- CLAMPS
- INSTRUCTION MANUAL

DETAILS



ON/OFF SWITCH



CLAMPS

DIMENSIONS

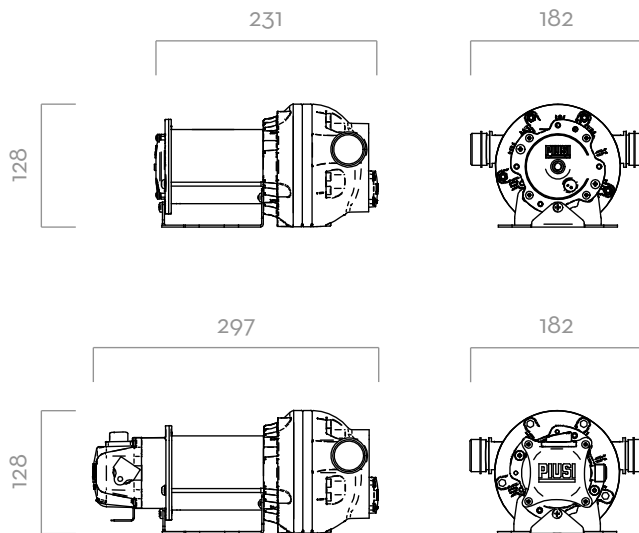

Dimensions expressed in millimeters

MATERIALS

- BODY: POLIPROPYLENE
- DIAPHRAGM: POLIPROPYLENE

TECHNICAL DATA

CODE	DESCRIPTION	FLUIDS TYPE	FLOW RATE		VOLTAGE			CABLES	INLET-OUTLET	ON/OFF	
			L/MIN	GPM	AC V/HZ DC VOLT	RPM	POWER WATT				AMP. MAX.
FOO204080	SUZZARABLU DC PUMP 12V		35	9,2	12	2600	260	22	YES	3/4"	YES
FOO204090	SUZZARABLU DC PUMP 24V		35	9,2	24	2600	310	10	YES	3/4"	YES



CAR FILLING



FUEL MANAGEMENT SYSTEMS



KITS



PUMPS



METERS



METERED NOZZLES

SQUALO35

FEATURES

- HEAVY DUTY
- REGENERATIVE TURBINE
- INTEGRATED PRESSURE REGULATOR
- BUILT-IN NON RETURN VALVE

SQUALO35 is the first submersible pump for AdBlue® to have been especially developed and tested for distribution systems. A centrifugal pump fitted with a turbine regenerator with non-return valve and a built-in innovative pressure regulation system that optimises flow rate performance levels. Consistent flow rate and accuracy during delivery dramatically reduce energy consumption levels. The compact size and special pump design make for easy installation and near complete emptying of the intended installation tank.

SUBLOCK is guaranteed IP55 on the top and is made of advanced technopolymer, with the exception for other parts that need extra robustness that are stainless steel. It integrates an anti-syphon system. Moreover, it represents the safest way to fix the SQUALO35 pump and related items to the tank. A practical pump hanging system that helps to prevent any transport damage to the tank, as it avoids impacts caused by movements or vibrations. It has been engineered to be fully compatible with most tanks available on the market.

PERFORMANCE

UP TO
35 L/MIN
FLOW RATE

AC
VOLTAGE
POWER

30 MM
DEAD LEVEL



SUBLOCK

Junction Cap for hose and cables
SQUALO35-on-tank connection:

- delivery hose
- power
- level indicator
- flow meter



SUBLOCK



SQUALO35

PACKAGING

CODE	WEIGHT		PACKAGING		
	KG	LBS	MM	INCH	PCS/BOX
FO020602A	7	15,4	510X240X150	20X9,4X5,6	1
FO0206A00	8,5	18,7	400X290X250	15,7X11,4X9,8	1



NOZZLES



FILTRATION



TANK MONITORING



HOSE REEL



ACCESSORIES



MERCHANDISE

INDEX



AIR



ANTIFREEZE



AdBlue®



BIODIESEL



DIESEL



FOOD



GASOLINE



GREASE



KEROSENE



OIL



WATER



WINDSCREEN

CHART

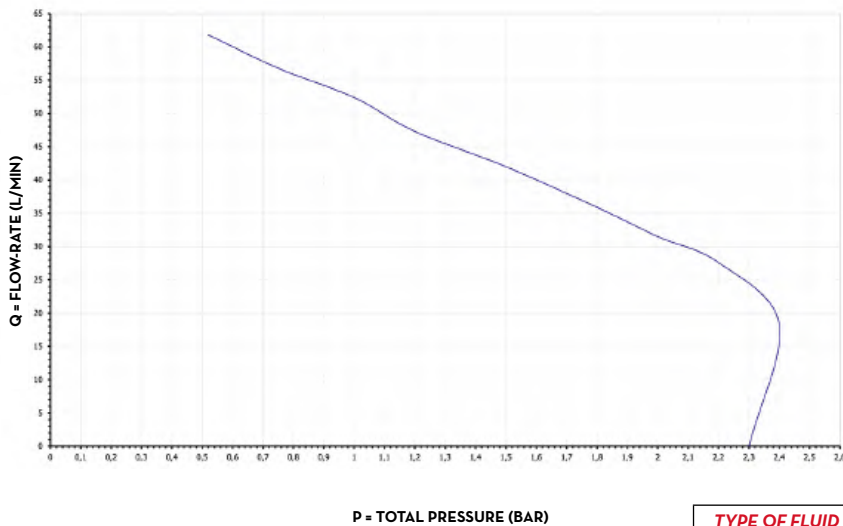

P = TOTAL PRESSURE (BAR)

TYPE OF FLUID WATER

TEMPERATURE 20°C

DIMENSIONS

SQUALO35

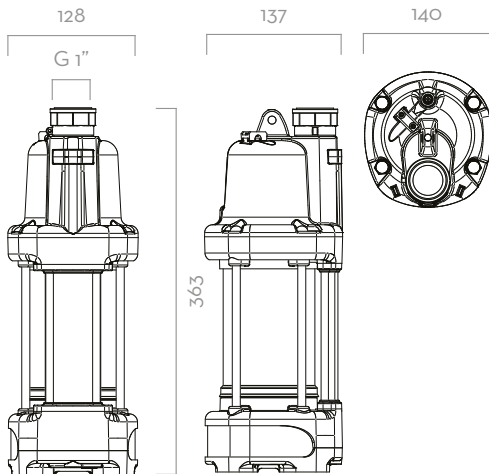

SUBLOCK

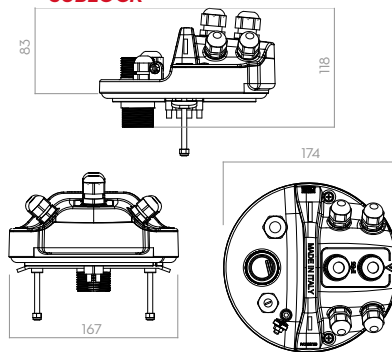

Dimensions expressed in millimeters

IN THE BOX

- SQUALO35
- KIT SQUALO35 SUBLOCK
- INSTRUCTION MANUAL

DETAILS



MESH STRAINER

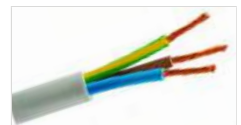

5 METERS POWER CORD



BUILT-IN NON RETURN VALVE



PRESSURE EQUALIZER

MATERIALS

- BODY: STAINLESS STEEL/TECHNOPOLYMER
- TURBINE: TECHNOPOLYMER

TECHNICAL DATA

CODICE	DESCRIPTION	FLUIDS TYPE	WORKING PRESSURE	FLOW RATE		VOLTAGE		DEAD LEVEL	POWER CORD
				L/MIN	GPM	CA V/HZ CC V	WATT		
FOO20602A	SQUALO35 230/50 TIMER		1,8 BAR 27 PSI	35	7,7	230/50	560	30 MM	5 M
FOO206A00	KIT SQUALO35 SUBLOCK 230/50-60HZ TIMER		1,8 BAR 27 PSI	35	7,7	230/50	560	30 MM	5 M



CAR FILLING



FUEL MANAGEMENT SYSTEMS



KITS



PUMPS



METERS



METERED NOZZLES

PRO ONE 15 - MP

FEATURES

- LONG-LIFE MEMBRANE
- BUILT-IN SILENCER
- WORKING CONDITIONS
- HEAVY INDUSTRIAL DUTY
- ROBUST DESIGN
- REDUCED AIR CONSUMPTION
- LOW NOISE LEVEL

PRO ONE 15 is a PIUSI pump designed to ensure maximum efficiency, durability, and ease of use. The new air distributor design allows quick disassembly with direct access from the outside, simplifying maintenance operations. Made of reinforced technopolymer, it ensures strength, reliability, and long service life. The anti-stall system with unbalanced valve reduces air consumption, improves operational efficiency, and lowers noise levels. Thanks to its Heavy Duty construction, PRO ONE 15 is ideal for intensive use, with a significant reduction in maintenance and operating costs.

PERFORMANCE

UP TO

50 L/MIN

FLOW RATE

MAX CAPACITY

7M

SELF PRIMING

MAX

7 BAR

AIR SUPPLY
PRESSURE

MAX

Ø 2,5MM

PASSING SOLID

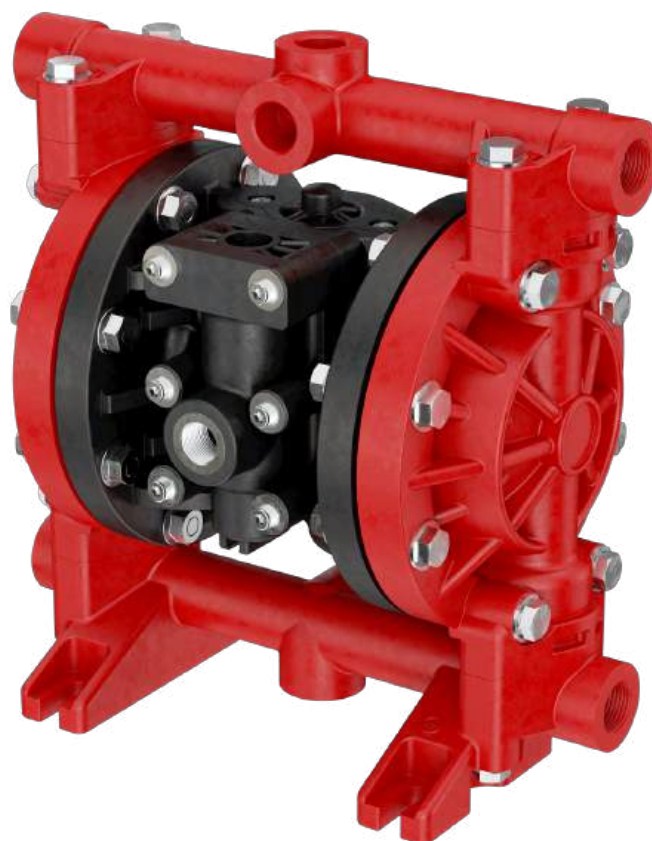

PRO ONE 15 - MP



PACKAGING

CODE	WEIGHT		PACKAGING		
	KG	LBS	MM	INCH	PCS/BOX
FO0808POO	4,9	10,8	292X178X285	11,4X7X11,2	1



NOZZLES



FILTRATION



TANK MONITORING



HOSE REEL



ACCESSORIES



MERCHANDISE

INDEX



AIR



ANTIFREEZE



AdBlue®



BIODIESEL



DIESEL



FOOD



GASOLINE



GREASE



KEROSENE



OIL



WATER



WINDSCREEN

CHART

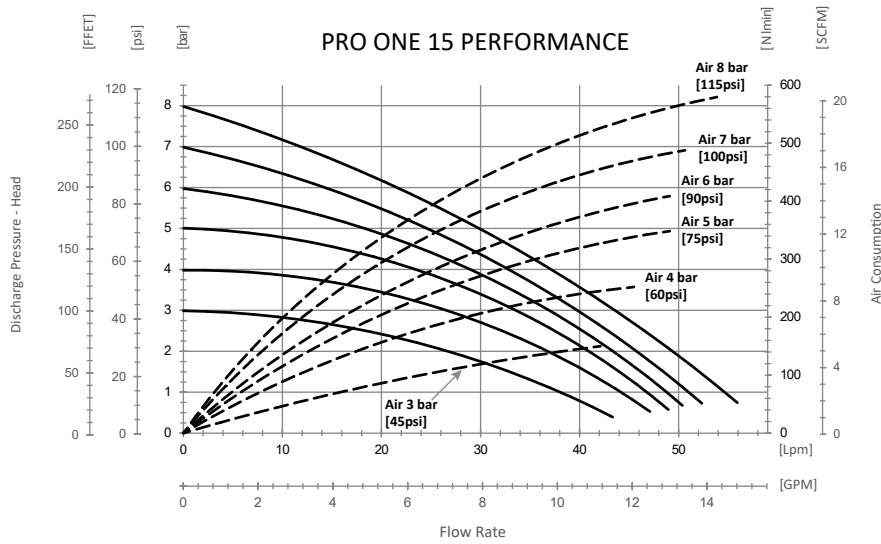

IN THE BOX

- PRO ONE 15 PUMP
- INSTRUCTION MANUAL

DETAILS



HEAVY DUTY MATERIALS



BODY IN REINFORCED POLYPROPYLENE



STURDY DESIGN

MATERIAL IN CONTACT WITH THE FLUID

- BODY: REINFORCED POLYPROPYLENE
- MEMBRANE AND GASKETS: SANTOPRENE®

DIMENSIONS

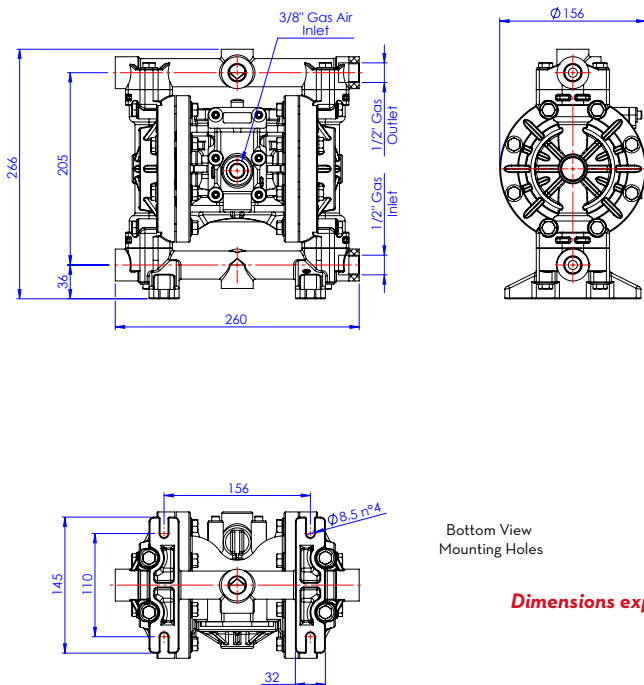

Bottom View Mounting Holes

Dimensions expressed in millimeters

TECHNICAL DATA

CODE	DESCRIPTION	FLUIDS TYPE	PUMP BODY	IN / OUT	FLOW RATE	DIAPHRAGM AIR SIDE / FLUID SIDE	INTAKE / DELIVERY CONNECTION	AIR CONNECTION	MAX SELF-PRIMING CAPACITY	MAX HEAD	MAX AIR SUPPLY PRESSURE	MAX Ø OF PASSING SOLID
					L/MIN				M			
FO0808POO	(EX) PRO ONE 15 - MP 50 L/MIN		REINFORCED POLYPROPYLENE	1/2" G	50	SANTOPRENE®	G 1/2" F	G 3/8" F	7	70	7	2,5



CAR FILLING



FUEL MANAGEMENT SYSTEMS



KITS



PUMPS



METERS



METERED NOZZLES

PRO ONE 25 - MP

FEATURES

- LONG-LIFE MEMBRANE
- BUILT-IN SILENCER
- WORKING CONDITIONS
- HEAVY INDUSTRIAL DUTY
- ROBUST DESIGN
- REDUCED AIR CONSUMPTION
- LOW NOISE LEVEL

PRO ONE 25 is a PIUSI pump designed to ensure maximum efficiency, durability, and ease of use. The new air distributor design allows quick disassembly with direct access from the outside, simplifying maintenance operations. Made of reinforced technopolymer, it ensures strength, reliability, and long service life. The anti-stall system with unbalanced valve reduces air consumption, improves operational efficiency, and lowers noise levels. Thanks to its Heavy Duty construction, PRO ONE 25 is ideal for intensive use, with a significant reduction in maintenance and operating costs.

PERFORMANCE

UP TO 160 L/MIN	MAX CAPACITY 7M
FLOW RATE	SELF PRIMING
MAX 7 BAR AIR SUPPLY PRESSURE	MAX Ø 5,1MM PASSING SOLID



PRO ONE 25 - MP



PACKAGING

CODE	WEIGHT		PACKAGING		
	KG	LBS	MM	INCH	PCS/BOX
FO0808P20	11,2	24,7	390X263X480	15,3X10,3X18,8	1



NOZZLES



FILTRATION



TANK MONITORING



HOSE REEL



ACCESSORIES



MERCHANDISE

INDEX



AIR



ANTIFREEZE



AdBlue®



BIODIESEL



DIESEL



FOOD



GASOLINE



GREASE



KEROSENE



OIL



WATER



WINDSCREEN

CHART

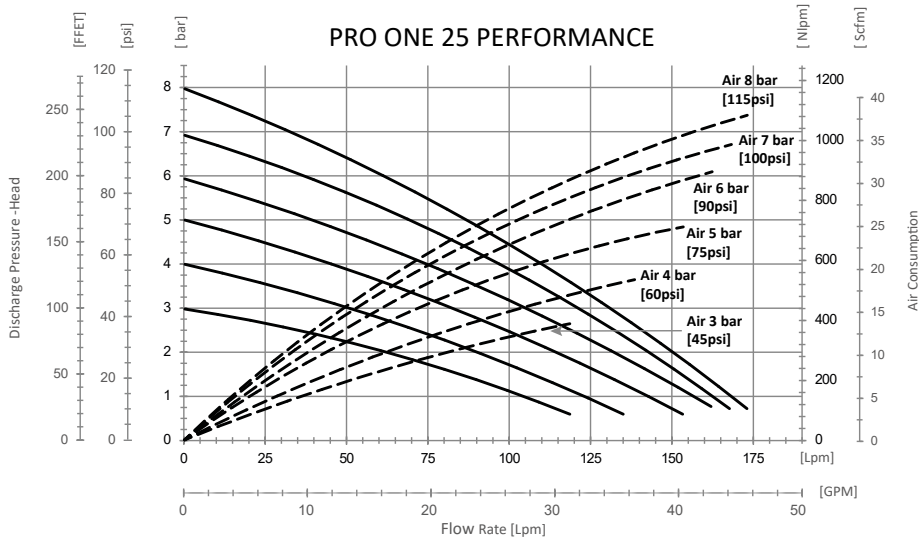

IN THE BOX

- PRO ONE 25 PUMP
- INSTRUCTION MANUAL

DETAILS



HEAVY DUTY MATERIALS



BODY IN REINFORCED POLYPROPYLENE



STURDY DESIGN

MATERIAL IN CONTACT WITH THE FLUID

- BODY: REINFORCED POLYPROPYLENE
- MEMBRANE AND GASKETS: SANTOPRENE®

DIMENSIONS

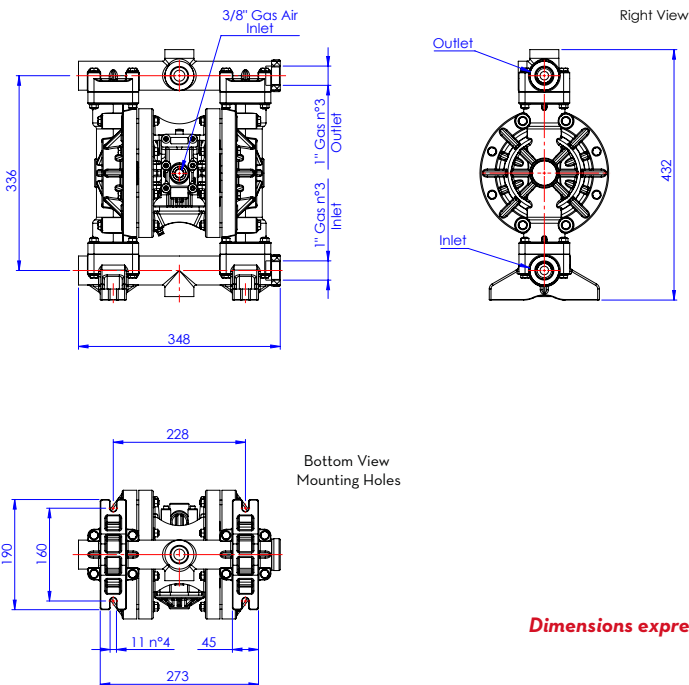

Dimensions expressed in millimeters

FICHA TÉCNICA

CODE	DESCRIPTION	FLUIDS TYPE	PUMP BODY	IN / OUT	FLOW RATE	DIAPHRAGM AIR SIDE / FLUID SIDE	INTAKE / DELIVERY CONNECTION	AIR CONNECTION	MAX SELF-PRIMING CAPACITY	MAX HEAD	MAX AIR SUPPLY PRESSURE	MAX Ø OF PASSING SOLID
					L/MIN							
FO0808P20	(EX) PRO ONE 25 - MP 160 L/MIN		REINFORCED POLYPROPYLENE	1" G	160	SANTOPRENE®	G 1" F	G 3/8" F	7	70	7	5,1



CAR FILLING



FUEL MANAGEMENT SYSTEMS



KITS



PUMPS



METERS



METERED NOZZLES

PIUSI HAND PUMP

FEATURES

- STURDY CONNECTOR
- HEAVY DUTY LEVER
- HIGH EFFICIENCY
- ADJUSTABLE SUCTION PIPE
- SELECTED MATERIALS
- BUILT-IN NON RETURN VALVE

The PIUSI HAND PUMP is a rotary vane pump suitable for transferring AdBlue®. Entirely designed, manufactured and certified in Italy, this sturdy pump guarantees a professional performance and it is indicated for all drum applications.

PERFORMANCE

UP TO

38 L

PER 100 REV.

FLOW RATE



PIUSI HAND PUMP



PACKAGING

CODE	WEIGHT		PACKAGING		N. BOXES/EUROPALLET	
	KG	LBS	MM	PCS/BOX		

WITHOUT HOSE

FO0332A0A	2,1	4,6	350X170X140	1	50	100
FO0332A4A	2,1	4,6	350X170X140	1	50	100

WITH HOSE

FO0332A2A	3,2	7	300X300X180	1	50	100
FO0332A8A	3,2	7	300X300X180	1	50	100
FO0332A5A	3,2	7	300X300X180	1	50	100
FO0332A7A	3,2	7	300X300X180	1	50	100
FO0332A9A	3,2	7	300X300X180	1	50	100



NOZZLES



FILTRATION



TANK MONITORING



HOSE REEL



ACCESSORIES



MERCHANDISE

INDEX



AIR



ANTIFREEZE



AdBlue®



BIODIESEL



DIESEL



FOOD



GASOLINE



GREASE



KEROSENE



OIL



WATER



WINDSCREEN

CHART

PIUSI HAND PUMP

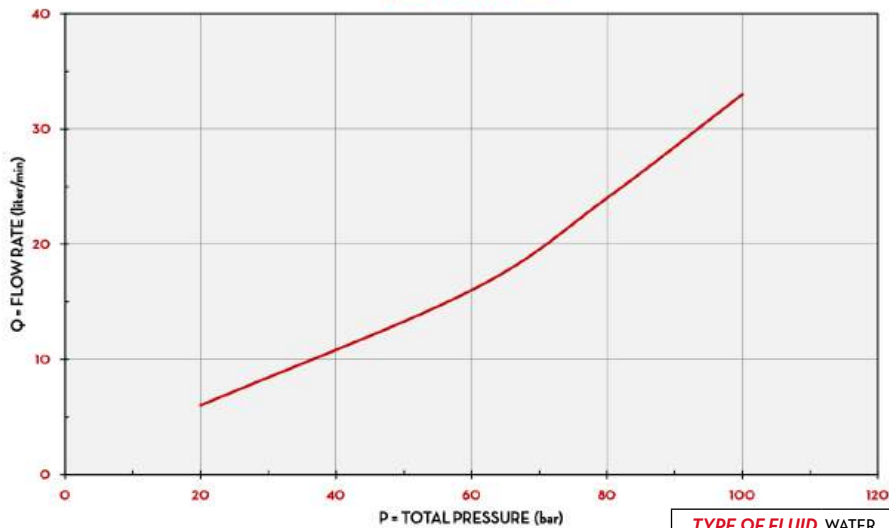

TYPE OF FLUID WATER

TEMPERATURE 20°C

IN THE BOX

- PIUSI HAND PUMP
- DRUM CONNECTOR
- SUCTION PIPE
- DELIVERY HOSE
- INSTRUCTION MANUAL

DETAILS



DRUM CONNECTOR



SUCTION PIPE



STAINLESS STEEL SPOUT

DIMENSIONS

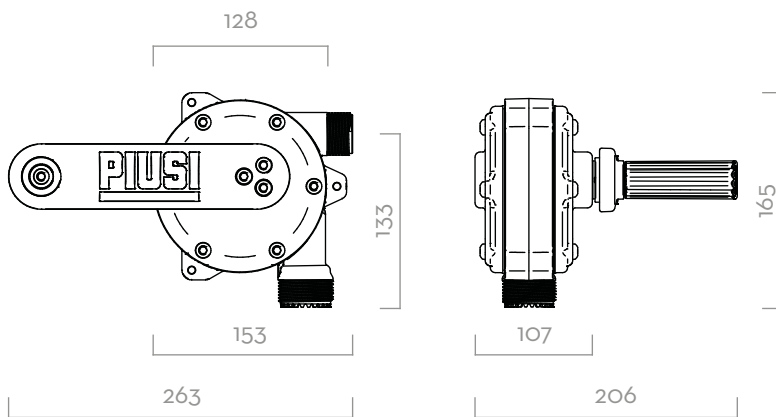

Dimensions expressed in millimeters

MATERIALS

- BODY: STAINLESS STEEL/TECHNOPOLYMER
- ROTOR: TECHNOPOLYMER
- VANES: TECHNOPOLYMER

TECHNICAL DATA

CODE	DESCRIPTION	FLUIDS TYPE	3D FILTER INCLUDED	CAPACITY PER 100 REVOLUTIONS		DRUM CONNECTOR	SUCTION TUBE	DELIVERY HOSE LENGHT
				L	USG			M
WITHOUT HOSE								
FO0332A0A	PIUSI HAND PUMP 56X4	Ad A W	NO	38	10	56X4	YES	-
FO0332A4A	PIUSI HAND PUMP UREA 2" BSP	Ad A W	NO	38	10	2" BSP	YES	-
WITH HOSE								
FO0332A2A	PIUSI HAND PUMP UREA 56X4 W/HOSE	Ad A W	NO	38	10	56X4	YES	2,5
FO0332A8A	PIUSI HAND PUMP UREA 2" BUT. W/H F	Ad A W	YES	38	10	2" BUTTRESS	YES	2,5
FO0332A5A	PIUSI HAND PUMP UREA 2" BSP W/HOSE	Ad A W	NO	38	10	2" BSP	YES	2,5
FO0332A7A	PIUSI HAND PUMP UREA 70X6 W/HOSE	Ad A W	NO	38	10	70X6	YES	2,5
FO0332A9A	PIUSI HAND PUMP UREA 56X4 70X6 2"BSP W/H	Ad A W	NO	38	10	2" BSP	YES	2,5



CAR FILLING



FUEL MANAGEMENT SYSTEMS



KITS



PUMPS



METERS



METERED NOZZLES

PIUSI HAND PUMP IBC

FEATURES

- IBC ERGONOMIC BRACKET
- HEAVY DUTY LEVER
- HIGH EFFICIENCY
- SELECTED MATERIALS

The PIUSI HAND PUMP IBC is a rotary vane pump suitable for transferring AdBlue®. It maintains all the main features of the PIUSI HAND PUMP while its ergonomic bracket guarantees a perfect IBC handling.

PERFORMANCE

UP TO

38 L

PER 100 REV

FLOW RATE



PIUSI HAND PUMP IBC



PACKAGING

CODE	WEIGHT		PACKAGING		
	KG	LBS	MM	INCH	PCS/BOX
WITHOUT FILTER					
FO0332BOA	2,1	4,6	350X170X5,5	13,8X6,7X5,5	1
WITH FILTER					
FO0332B1A	3,2	7	300X300X180	18,8X11,8X7,1	1



NOZZLES



FILTRATION



TANK MONITORING



HOSE REEL



ACCESSORIES



MERCHANDISE

INDEX



AIR



ANTIFREEZE



AdBlue®



BIODIESEL



DIESEL



FOOD



GASOLINE



GREASE



KEROSENE



OIL



WATER



WINDSCREEN

CHART

PIUSI HAND PUMP IBC

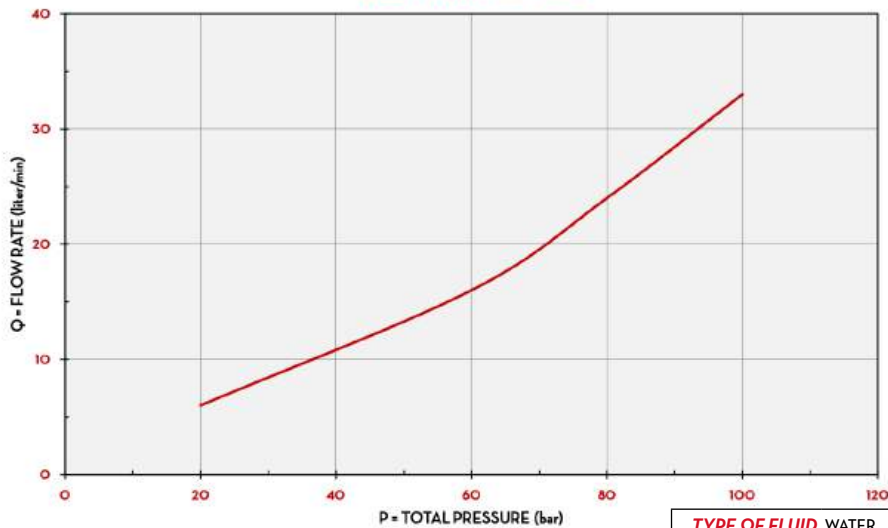

TYPE OF FLUID WATER

TEMPERATURE 20°C

DIMENSIONS

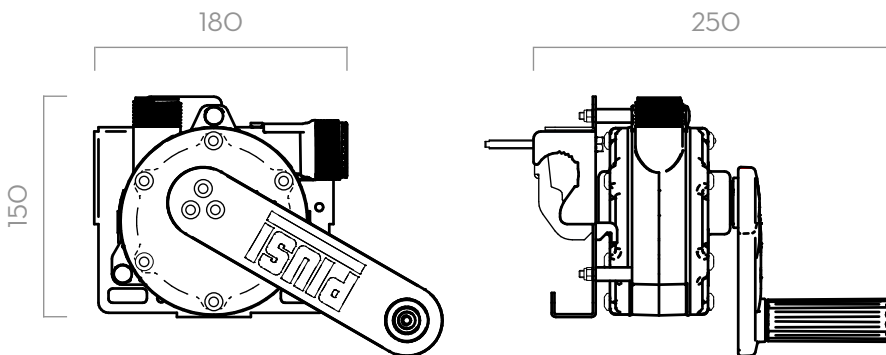

Dimensions expressed in millimeters

IN THE BOX

- PIUSI HAND PUMP IBC
- IBC MOUNT BRACKET
- DELIVERY HOSE
- 3D FILTER (ON REQUEST)
- INSTRUCTION MANUAL

DETAILS



STAINLESS STEEL SPOUT



STURDY LEVER



IBC BRACKET

MATERIALS

- BODY: STAINLESS STEEL, TECHNOPOLYMER
- ROTOR: TECHNOPOLYMER
- VANES: TECHNOPOLYMER

TECHNICAL DATA

CODE	DESCRIPTION	FLUIDS TYPE	CAPACITY PER 100 REVOLUTIONS		IBC BRACKET	SUCTION HOSE	DELIVERY HOSE LENGTH	3D FILTER
			L	USG				
WITHOUT FILTER								
FO0332BOA	PIUSI HAND PUMP FOR IBC W/O FILTER		38	10	YES	1	2,5	NO
WITH FILTER								
FO0332B1A	PIUSI HAND PUMP UREA SIDE W/FILTER		38	10	YES	1	2,5	YES

IBC NOT INCLUDED



CAR FILLING



FUEL MANAGEMENT SYSTEMS



KITS



PUMPS



METERS



METERED NOZZLES

SUZZARABLU

FEATURES

- READY / EASY TO USE
- SUITABLE FOR ANY OPERATING CONDITION

The PIUSI SUZZARABLU HAND PUMP is the basic version of hand pump (piston) offered by PIUSI. They are manufactured in plastic according to the ISO 22241.

PERFORMANCE

3M

HOSE LENGTH



SUZZARABLU HAND PUMP



PACKAGING

CODE	WEIGHT		PACKAGING		N. BOXES/EUROPALLET	
	KG	LBS	MM	PCS/BOX		

PISTON HAND PUMPS

FO033209A	1,5	3,3	160X340X140	1	72	102
FO033210A	3,4	7,5	510X240X150	1	48	66



NOZZLES



FILTRATION



TANK MONITORING



HOSE REEL



ACCESSORIES



MERCHANDISE

INDEX



AIR



ANTIFREEZE



AdBlue®



BIODIESEL



DIESEL



FOOD



GASOLINE



GREASE



KEROSENE



OIL



WATER



WINDSCREEN

CHART

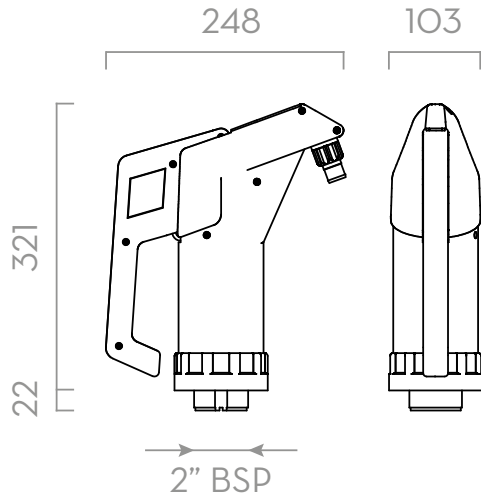

Dimensions expressed in millimeters

IN THE BOX

- SUZZARABLU HAND PUMP
- DELIVERY HOSE (ON REQUEST)
- SUCTION PIPE
- INSTRUCTION MANUAL

DETAILS



LEVER



SPOUT

MATERIALS

- BODY: PLASTIC
- ROTOR: PLASTIC
- VANES: PLASTIC

TECHNICAL DATA

CODE	DESCRIPTION	FLUIDS TYPE	SPOUT		HOSE		DIP PIPE	COMPLETE KIT	MAUSER AND GREIF ADAPTER FOR DRUM
			BSP	LENGHT	Ø				
FO033209A	PISTON HAND PUMP (WITH DIP PIPE)		3/4"	-	-	-	YES	-	-
FO033210A	PISTON HAND PUMP (WITH COMPLETE KIT)		3/4"	3 M	3/4"	3/4"	YES	YES	YES

PISTON HAND PUMP



PUMPS ACCESSORIES

DC PUMP



SUZZARABLU PUMP DC	CODE	DESCRIPTION
	R16175010	KIT HANDLE



R16175010



HAND PUMPS

PIUSI HAND PUMP	CODE	DESCRIPTION
	FOO611D30	3D FILTER + HOUSING
	R1512800A	ADAPTER M/F 2" - S7OX6 ADBLUE
	F19158000	DRUM CONNECTOR 56X4
	F19159000	DRUM CONNECTOR 2" BUTTRESS
	F19157000	DRUM CONNECTOR 2" BSP
	F19157010	DRUM CONNECTOR 70X6







FOO611D30
F19158000 / F19159000
F19157010 / F19157000
R1512800A

PIUSI HAND PUMP IBC	CODE	DESCRIPTION
	F20189000	AF2 56X4 BUTTRESS - 1" BSP
	F20190000	AF2 2" BUTTRESS - 1" BSP
	F20257000	AF2 2" BSP - 1" BSP
	F20258000	AF2 2" 70X6 - 1" BSP
	F15452000	SEC + HOSETAIL 90°
	F15515000	EXT SUCTION HOSE IBC TANK W/FOOT VALVE
	F15606000	KIT RIGID SUCTION HOSE SUZZARA BLUE DRUM
	F15236000	ADATTATORE M\F 2IN - 56X4 ADBLUE





F20189000 / F20190000
F20257000 / F20258000
F15606000
F15452000

FOO611D30
F15515000
F15236000

SUZZARABLU HAND PUMP	CODE	DESCRIPTION
	R1512800A	ADAPTER M/F 2" - S7OX6 ADBLUE
	F15236000	ADATTATORE M\F 2IN - 56X4 ADBLUE



R1512800A
F15236000



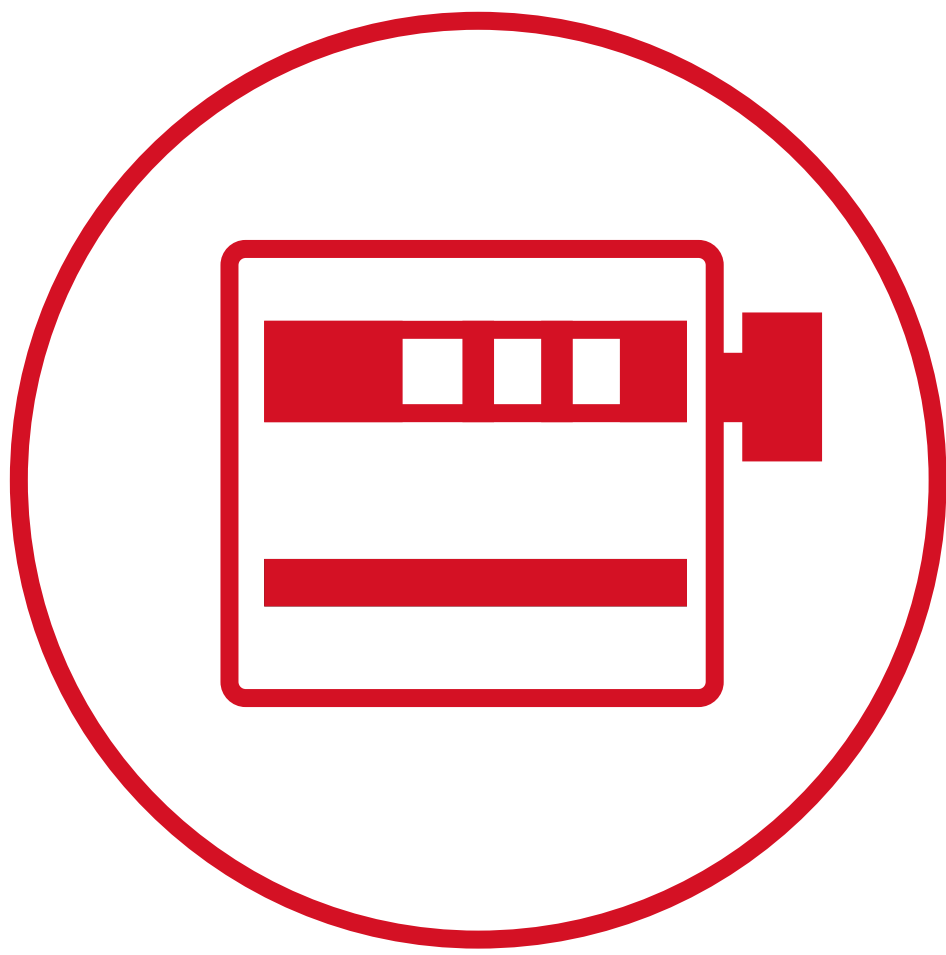

METERS





CAR FILLING



FUEL MANAGEMENT SYSTEMS



KITS



PUMPS



METERS



METERED NOZZLES

K24

FEATURES

- FLOW RATE INDICATION
- STANDARD AAA BATTERIES
- ROTABLE DISPLAY
- LOW BATTERY CONSUMPTION
- RUBBER PROTECTION

The K24 is PIUSI's exclusive turbine meter. Its compact design, accuracy and ease of use makes this flow meter an excellence in measuring AdBlue®. It is equipped with a compact and easy readable display that can be rotated in 4 different positions.



K24

PERFORMANCE

UP TO 120 L/MIN	10 BAR MAX
FLOW RATE	OPERATING PRESSURE
±1%	0,3%
ACCURACY	REPEATABILITY



K24 PULSE METER

PACKAGING

CODE	WEIGHT		PACKAGING		
	KG	LBS	MM	INCH	PCS/BOX
FOO40710A	0,4	0,9	BLISTER	BLISTER	1
FOO40721B	0,4	0,9	115X160X135	4,5X3X5,3	1



NOZZLES



FILTRATION



TANK MONITORING



HOSE REEL



ACCESSORIES



MERCHANDISE

INDEX



AIR



ANTIFREEZE



AdBlue®



BIODIESEL



DIESEL



FOOD



GASOLINE



GREASE



KEROSENE



OIL



WATER



WINDSCREEN

CHART

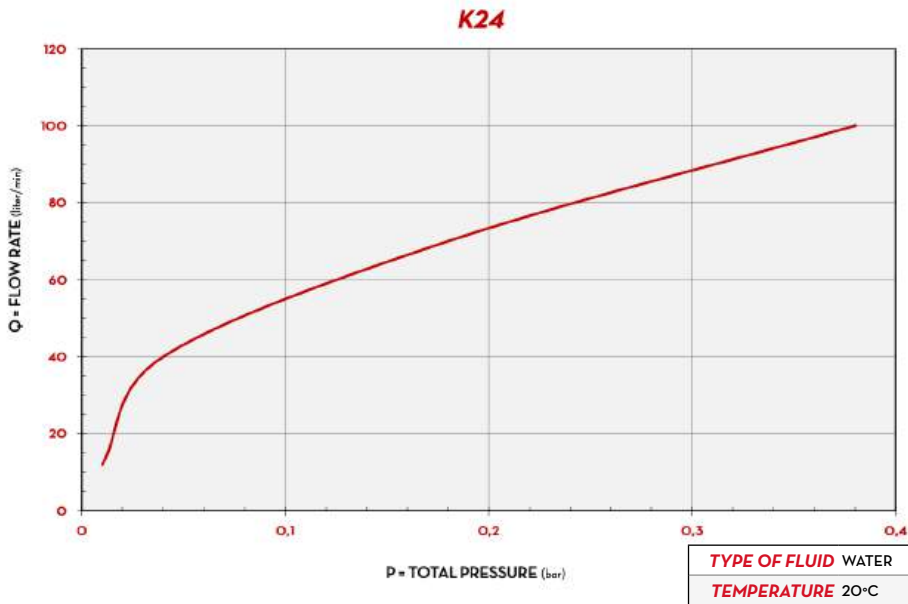

IN THE BOX

- K24 METER
- STAINLESS STEEL SOCKET
- INSTRUCTION MANUAL

DETAILS



ROTABLE DISPLAY



TURBINE

DIMENSIONS

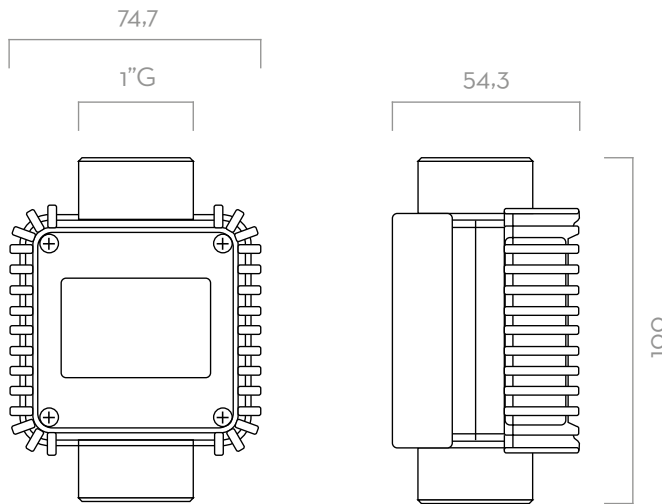

Dimensions expressed in millimeters

MATERIALS

- BODY: TECHNOPYLIMER
- TURBINE: TECHNOPYLIMER

TECHNICAL DATA

CODE	DESCRIPTION	FLUIDS TYPE	FLOW RATE		PRESSURE		DISPLAY	PULSE OUT (P/L)	
			L/MIN	GPM	BAR	PSI		PULSE VERSION	DISPLAY VERSION
FOO40710A	K24 METER (1 SOCKET)	Ad W	5 · 120	1,3-26,4	10	145	YES	-	-
FOO40721B	K24 PULSE-METER (1 SOCKET) (87,73 PULSE/L)	Ad W	5 · 120	1,3-26,4	10	145	NO	88	-



CAR FILLING



FUEL MANAGEMENT SYSTEMS



KITS



PUMPS



METERS



METERED NOZZLES

TURBINOX

FEATURES

- LONG LASTING
- INDUSTRIAL APPLICATION
- STAINLESS STEEL BODY
- VERSATILE

The PIUSI TURBINOX is a turbine pulse meter suitable for transferring AdBlue®. Its stainless steel body guarantees a long-lasting resistance and makes this meter perfect for plant installations.

PERFORMANCE

UP TO 40 L/MIN	20 BAR MAX
FLOW RATE	OPERATING PRESSURE
±1%	0,4%
ACCURACY	REPEATABILITY



TURBINOX - TURBINOX 90°



PACKAGING

CODE	WEIGHT		PACKAGING		
	KG	LBS	MM	INCH	PCS/BOX
FOO420000A	0,5	1,1	80X80X75	3,1X3,1X3	1
FOO420001A	0,5	1,1	80X80X75	3,1X3,1X3	1



NOZZLES



FILTRATION



TANK MONITORING



HOSE REEL



ACCESSORIES



MERCHANDISE

INDEX



AIR



ANTIFREEZE



AdBlue®



BIODIESEL



DIESEL



FOOD



GASOLINE



GREASE



KEROSENE



OIL



WATER



WINDSCREEN

CHART

TURBINOX

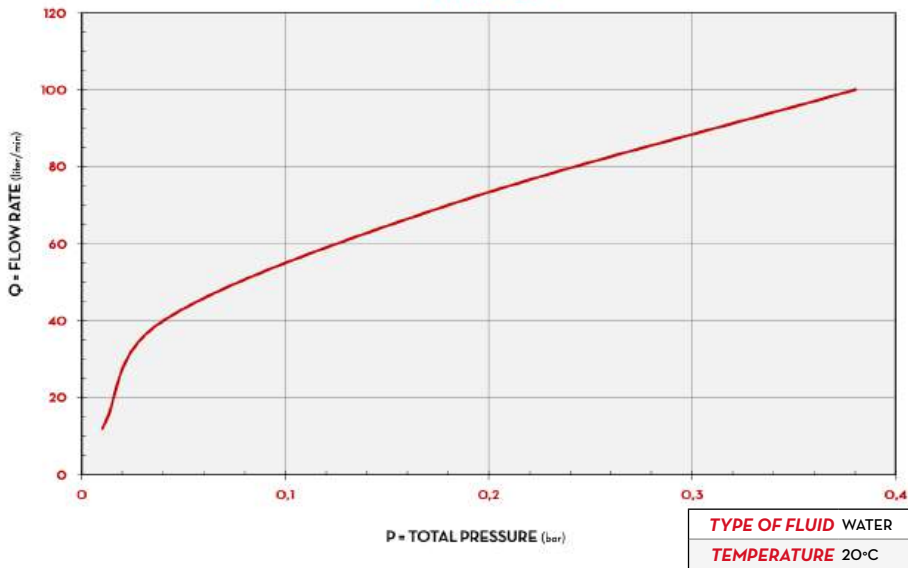

IN THE BOX

- TURBINOX METER
- INSTRUCTION MANUAL

DETAILS



TURBINE

DIMENSIONS

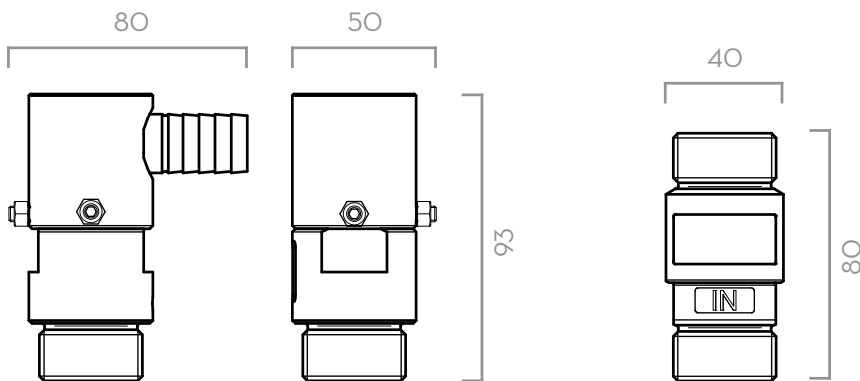

Dimensions expressed in millimeters

MATERIALS

- BODY: STAINLESS STEEL
- TURBINE: TECHNOPOLYMER

TECHNICAL DATA

CODE	DESCRIPTION	FLUIDS TYPE	FLOW RATE		PRESSURE		DISPLAY	PULSE OUT (P/L)	
			L/MIN	GPM	BAR	PSI		PULSE VERSION	DISPLAY VERSION
FOO42000A	TURBINOX INLINE PULSE METER	Ad W	10 - 40	2,6-10,6	20	290	NO	90	-
FOO42001A	TURBINOX 90° TURBINE PULSE METER	Ad W	10 - 40	2,6-10,6	20	290	NO	90	-



CAR FILLING



FUEL MANAGEMENT SYSTEMS



KITS



PUMPS



METERS



METERED NOZZLES

MK325 METER

FEATURES

- MID EVALUATION CERTIFICATE
- LOW MAINTENANCE COSTS
- BIDIRECTIONAL MEASUREMENT
- ATEX CERTIFICATION

The PIUSI MK325 is a state-of-the-art flow meter, specifically designed to ensure accurate MID measurement of AdBlue®. It is compatible with both fixed and mobile dispensing systems.

PERFORMANCE

UP TO 5-35 L/MIN	20 BAR MAX
FLOW RATE	OPERATING PRESSURE
±0,3%	0,2%
ACCURACY	REPEATABILITY



MK325
COD. F00476X20

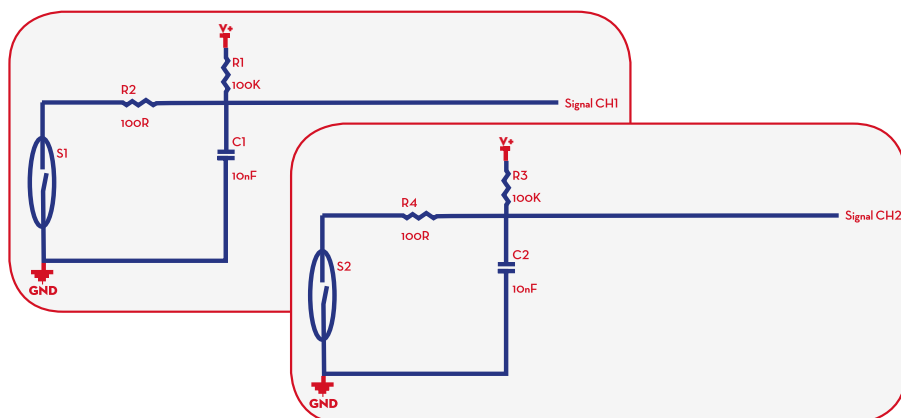

ELECTRICAL SCHEME

PACKAGING

CODE	WEIGHT		PACKAGING		
	KG	LBS	MM	INCH	PCS/BOX
F00476X20	1,3	2,64	190X140X160	7,48X5,51X6,3	1



NOZZLES



FILTRATION



TANK MONITORING



HOSE REEL



ACCESSORIES



MERCHANDISE

INDEX



AIR



ANTIFREEZE



AdBlue®



BIODIESEL



DIESEL



FOOD



GASOLINE



GREASE



KEROSENE



OIL



WATER



WINDSCREEN

CHART

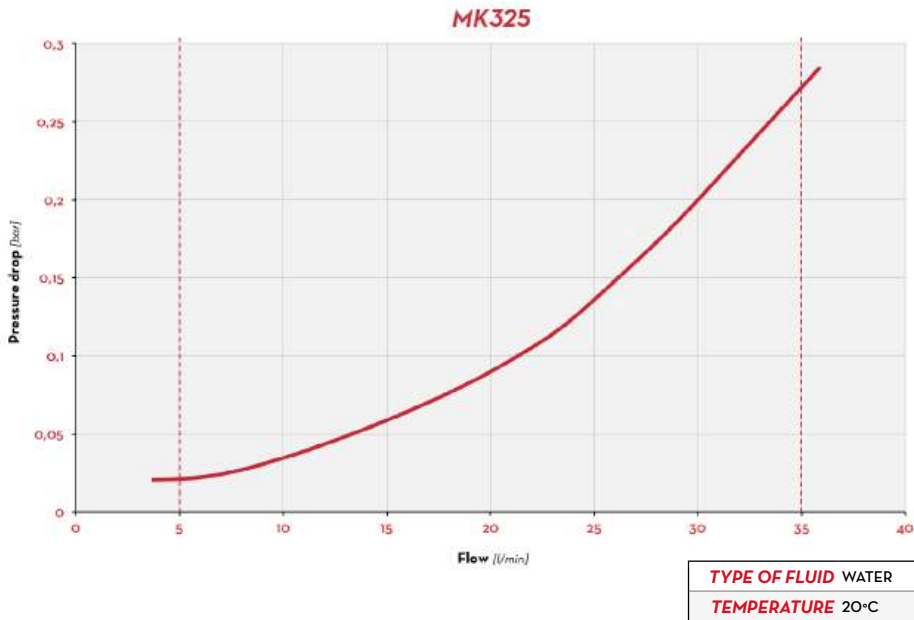

DIMENSIONS

MK325
COD. F00476X20

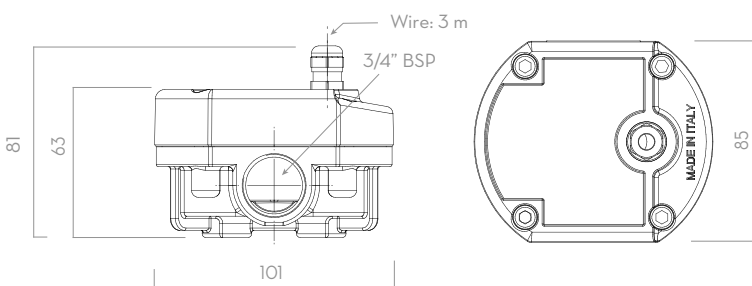

Dimensions expressed in millimeters

IN THE BOX

- MK325 METER
- INSTRUCTIONS WITH CALIBRATION FACTOR
- INSTRUCTION MANUAL

DETAILS



3M CABLE LENGTH



ATEX CERTIFIED



PEEK GEAR



BIDIRECTIONAL MEASURING

MATERIALS

- BODY: STAINLESS STEEL
- CABLE BOX: ALLUMINIUM
- GEAR: PEEK
- SEALS: NPR

TECHNICAL DATA

CODE	DESCRIPTION	FLUIDS TYPE	FLOW RATE		PRESSURE		ATEX CERTIFICATION	DEGREE OF PROTECTION	PULSE OUT (P/L)	
			L/MIN	GPM	BAR	PSI			PULSE VERSION	DISPLAY VERSION
F00476X20	(EX) MK325 5-35 Z2 3/4" BSP (MID)		5 - 35	1,3 - 8-9,3	20	290	EX-M Z2	IP67	APPROX. 160	NO



CAR FILLING



FUEL MANAGEMENT SYSTEMS



KITS



PUMPS



METERS



METERED NOZZLES

REMOTE DISPLAY

FEATURES

- LARGE SCREEN DISPLAY
- NON RESETTABLE TOTAL
- STANDARD BATTERY

REMOTE DISPLAY for remote control (via max. 15 m. cable) of pulse meters. The large screen displays the quantity delivered and the non resettable total. Equipped with software applications for calibrating meters. Available as both basic display device and as pulse emitter. Indispensable for receivers designed to recognise only discreet quantities of impulses.

PERFORMANCE

EVERY
PULSE METER

COMPATIBILITY

UP TO
100
PULSES/LITER

FLOW RATE



REMOTE DISPLAY



PACKAGING

CODE	WEIGHT		PACKAGING		
	KG	LBS	MM	INCH	PCS/BOX
FOO49504A	1,2	2,6	200X120X140	8,9X4,9X5,9	1
FOO49503B	1,2	2,6	225X125X150	8,9X4,9X5,9	1



NOZZLES



FILTRATION



TANK MONITORING



HOSE REEL



ACCESSORIES



MERCHANDISE

INDEX



AIR



ANTIFREEZE



AdBlue®



BIODIESEL



DIESEL



FOOD



GASOLINE



GREASE



KEROSENE



OIL



WATER



WINDSCREEN

FUNCTIONING

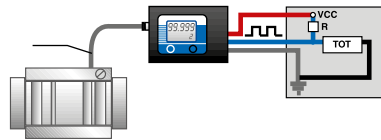
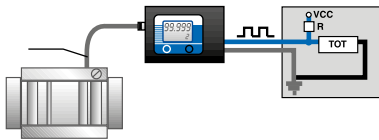
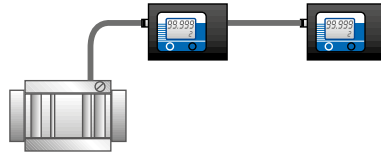
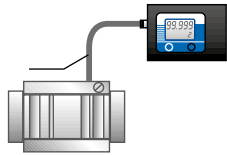

IN THE BOX

- REMOTE DISPLAY
- BRACKET
- INSTRUCTION MANUAL

DETAILS



5 DIGITS PARTIAL TOTAL



ADJUSTABLE BRACKET

DIMENSIONS

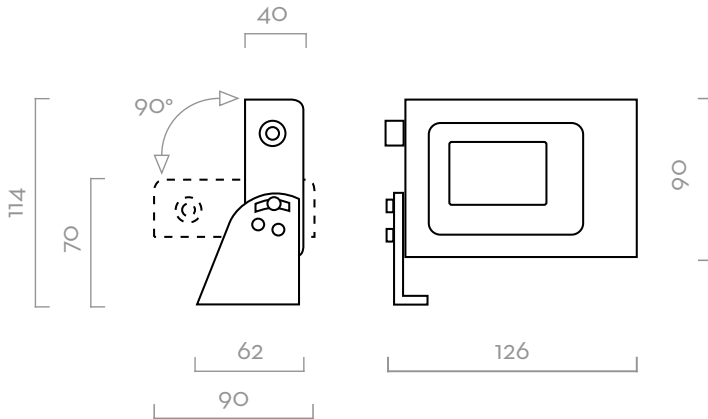

Dimensions expressed in millimeters

TECHNICAL DATA

CODE	DESCRIPTION	FLUIDS TYPE	FLANGE	INLET OUTLET
FOO49504A	DISPLAY PULSE IN		FOR ALL PIUSI PULSE OUT REMOTE DISPLAY	PULSE IN
FOO49503B	DISPLAY PULSE OUT ADBLUE®		TURBINOX / K24 PULSER	PULSE OUT

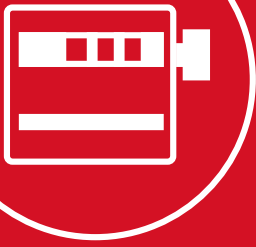

METERS ACCESSORIES

ELECTRONIC METERS

K24	CODE	DESCRIPTION
	FOO49503B	REMOTE DISPLAY PULS OUT 100 UREA
	FOO49504A	REMOTE DISPLAY NO PULS OUT - UREA
	F15484000	HOSETAIL D.19 90° W/RING NUT FOR K24
	F15776000	SWIVEL M-F 1IN GAS PLASTIC MANUAL NOZZLE
	F16073000	STAINLESS STEEL SOCKET 1"(20 PCS)BSP/BSP



TURBINOX	CODE	DESCRIPTION
	FOO49503B	REMOTE DISPLAY PULS OUT 100 UREA
	FOO49504A	REMOTE DISPLAY NO PULS OUT - UREA
	F15484000	HOSETAIL D.19 90° W/RING NUT FOR K24
	F15776000	SWIVEL M-F 1IN GAS PLASTIC MANUAL NOZZLE
	F16073000	STAINLESS STEEL SOCKET 1"(20 PCS)BSP/BSP



MK325	CODE	DESCRIPTION
	F19914000	KIT WALL MK324





METERED NOZZLES



CAR FILLING



FUEL MANAGEMENT SYSTEMS



KITS



PUMPS



METERS



METERED NOZZLES

SB325_X METER/SB325_X METER CAR

FEATURES

- HEAVY DUTY
- VERSATILE
- BUILT-IN TURBINE METER
- BREAK-AWAY SYSTEM
- MULTI-FUNCTIONAL DISPLAY
- SPECIFIC SPOUT FOR CARS/LIGHT COMMERCIAL VEHICLES
- EASY AND PRACTICAL

The PIUSI SB325_X METER and SB325_X METER CAR are the patented automatic metered nozzles by PIUSI for AdBlue®. They are engineered according to ISO/ FDIS 22241-4:2009 and composed by an innovative technopolymer casing, a break-away system, a stainless steel spout and the K24 meter with 1% accuracy.

The SB325_X METER CAR has a different shape compared to SB325_X METER and is 2,4 cm shorter, this to allow a better usability and performance in the car/commercial vehicle sector. SB325_X METER CAR is compatible with all PIUSI AdBlue® pumps. Use with pumps other than the PIUSI range must be subject to prior verification of the system's flow rate.

PERFORMANCE

±1%

ACCURACY

SB325_X METER

UP TO

45 L/MIN

FLOW RATE

3,5 BAR

MAX

OPERATING PRESSURE

SB325_X METER CAR

5-27 L/MIN

FLOW RATE

3 BAR

MAX

OPERATING PRESSURE



PACKAGING

CODE	WEIGHT		PACKAGING		
	KG	LBS	MM	INCH	PCS/BOX
FOO61701A	1,0	2,2	447X178X63	17,6X7X2,5	1
FOO61722O	1,2	2,6	450X180X90	17,7X7X3,5	1



NOZZLES



FILTRATION



TANK MONITORING



HOSE REEL



ACCESSORIES



MERCHANDISE

INDEX



AIR



ANTIFREEZE



AdBlue®



BIODIESEL



DIESEL



FOOD



GASOLINE



GREASE



KEROSENE



OIL



WATER



WINDSCREEN

CHART

SB325_X / SB325_CAR

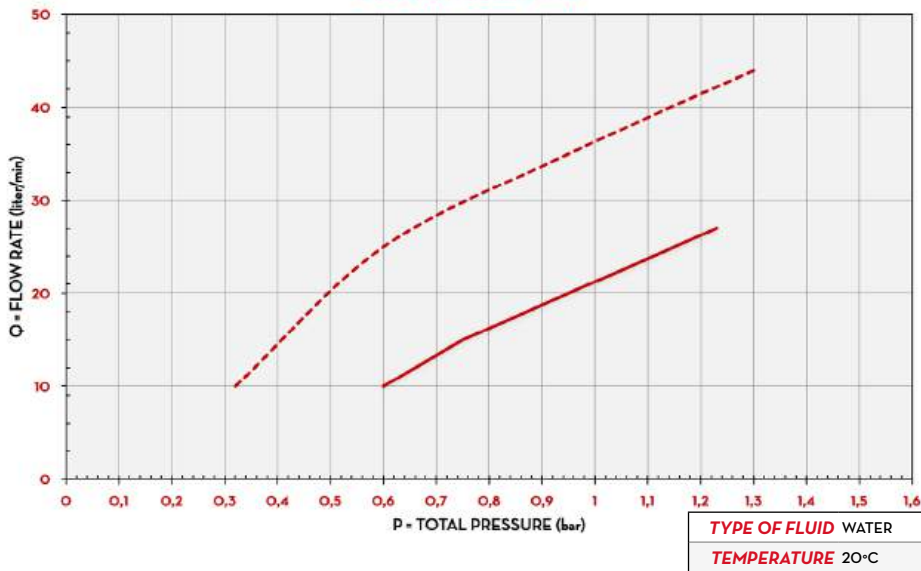

DIMENSIONS

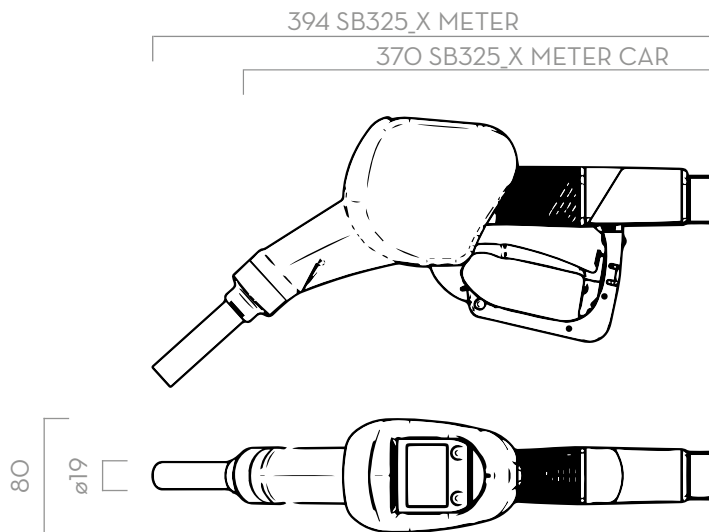

Dimensions expressed in millimeters

IN THE BOX

- PISTOLA SB325_X METER / SB325_X METER CAR NOZZLE
- INSTRUCTION MANUAL

DETAILS



MULTI-FUNCTIONAL DISPLAY



BREAK-AWAY SYSTEM

MATERIALS

- SPOUT: STAINLESS STEEL
- BODY: TECHNOPYMER
- TURBINE: TECHNOPYMER

TECHNICAL DATA

CODE	DESCRIPTION	FLUIDS TYPE	FLOW RATE		MAGNETIC ADAPTOR	METER	PRESSURE	INLET	SWIVEL	SPOUT
			L/MIN	GPM			BAR			EXT. Ø
FO061701A	AUTOMATIC NOZZLE SB325_X METER		45	12	NO	SI	3,5	3/4"	YES	19 MM
FO0617220	AUTOMATIC NOZZLE SB325_X METER CAR		27	7	NO	SI	3	3/4"	YES	19 MM



METERED NOZZLES ACCESSORIES

AUTOMATIC METERED NOZZLES

SB325_X METER	CODE	DESCRIPTION
	F1917400A	KIT FOR SB325_X WITH MISFILLING AND MAGNETIC ADAPTOR
	F18400000	PIUSI MAGNETIC ADAPTOR
	F15165000	ELAFIX 40 MAGNETIC ADAPTOR



F1917400A F15165000 F18400000





NOZZLES

A large, solid red triangle is positioned in the bottom right corner of the page, pointing towards the top right.



CAR FILLING



FUEL MANAGEMENT SYSTEMS



KITS



PUMPS



METERS



METERED NOZZLES

SB325_X/SB325_X CAR

FEATURES

- HEAVY DUTY
- VERSATILE
- BREAK-AWAY SYSTEM
- ERGONOMIC DESIGN
- SPECIFIC SPOUT FOR CARS/LIGHT COMMERCIAL VEHICLES
- EASY AND PRACTICAL

Specifically developed for AdBlue® refilling on cars/light commercial vehicle and heavy vehicles, SB325_X and SB325_X CAR are patented automatic nozzles by PIUSI equipped with break-away system and stainless steel spout. Designed in compliance with International Standards ISO/ FDIS 22241-4:2009, these two innovative automatic nozzles also feature a reliable, ergonomic and flexible shell that protects the nozzles against weathering and UV radiation.

The SB325_X CAR has a different shape compared to SB325_X and is 2,4 cm shorter, this to allow a better usability and performance in the car/commercial vehicle sector. SB325_X CAR is compatible with all PIUSI AdBlue® pumps. Use with pumps other than the PIUSI range must be subject to prior verification of the system's flow rate.

PERFORMANCE

SB325_X

UP TO

45 L/MIN

FLOW RATE

3,5 BAR

MAX

OPERATING PRESSURE

SB325_X CAR

UP TO

27 L/MIN

FLOW RATE

3 BAR

MAX

OPERATING PRESSURE

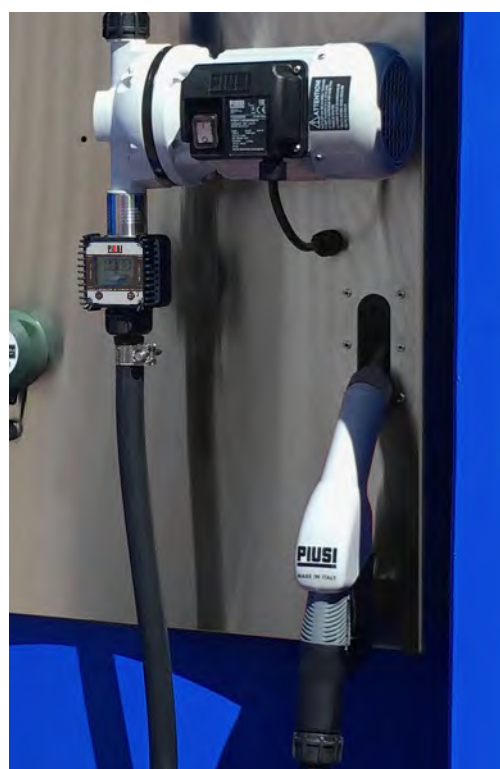

PACKAGING

CODE	WEIGHT		PACKAGING		
	KG	LBS	MM	INCH	PCS/BOX
FOO61700A	0,7	1,5	447X178X85	17,6X7X2,5	1
FOO617210	1,1	2,4	450X180X70	17,7X7X2,7	1



NOZZLES



FILTRATION



TANK MONITORING



HOSE REEL



ACCESSORIES



MERCHANDISE

INDEX



AIR



ANTIFREEZE



AdBlue®



BIODIESEL



DIESEL



FOOD



GASOLINE



GREASE



KEROSENE



OIL



WATER



WINDSCREEN

CHART

SB325_X / SB325_CAR

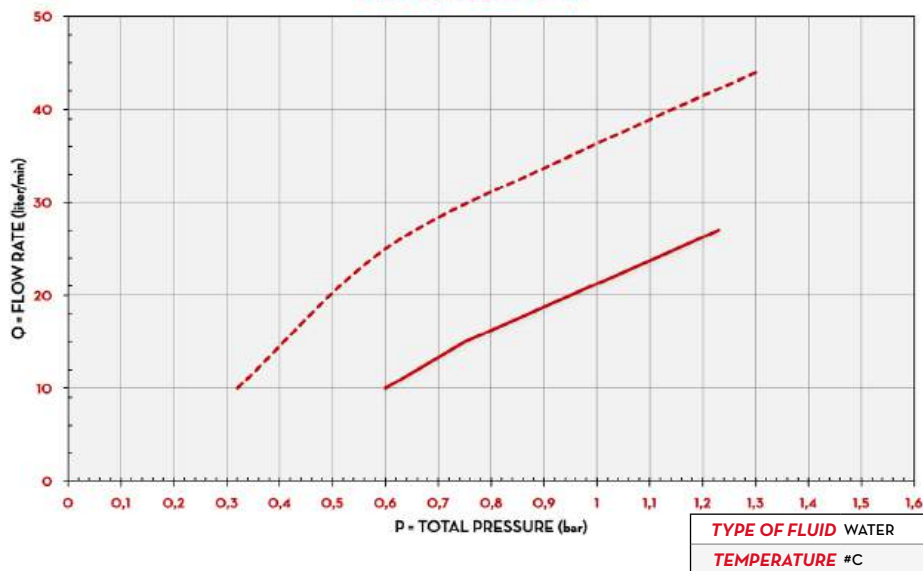

IN THE BOX

- SB325_X/SB325_CAR NOZZLE
- INSTRUCTION MANUAL

DETAILS



STAINLESS STEEL SPOUT



BREAK-AWAY SYSTEM

DIMENSIONS

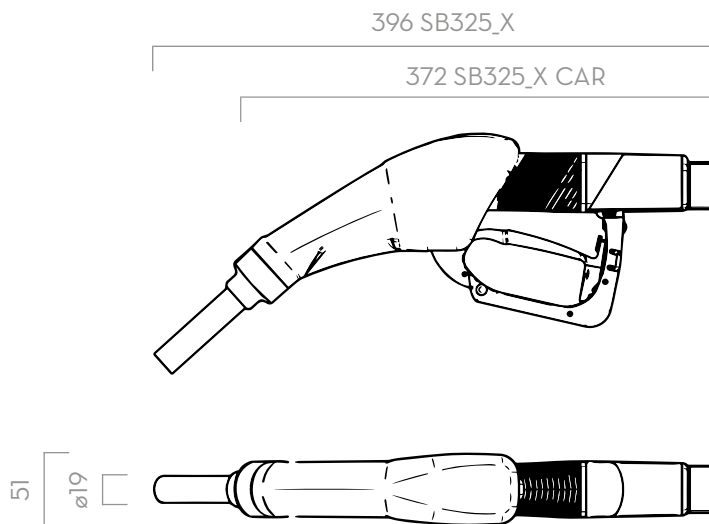

Dimensions expressed in millimeters

MATERIALS

- SPOUT: STAINLESS STEEL
- BODY: TECHNOPYLIMER

TECHNICAL DATA

CODE	DESCRIPTION	FLUIDS TYPE	FLOW RATE		MAGNETIC ADAPTOR	METER	PRESSURE BAR	INLET	SWIVEL	SPOUT EXT. Ø
			L/MIN	GPM						
FO061700A	AUTOMATIC NOZZLE SB325_X		45	12	NO	NO	3,5	3/4"	YES	19 MM
FO0617210	AUTOMATIC NOZZLE SB325_X_CAR		27	7	NO	NO	3	3/4"	YES	19 MM



CAR FILLING



FUEL MANAGEMENT SYSTEMS



KITS



PUMPS



METERS



METERED NOZZLES

SUZZARABLUE A60

FEATURES

- **READY TO USE**
- **STURDY DESIGN**
- **STAINLESS STEEL BODY**

The PIUSI SUZZARABLUE A60 is an automatic nozzle suitable to dispense AdBlue® featuring a device that stops the dispensing when the tank is full. It comes with a hose-tail fitting.

PERFORMANCE

UP TO

40 L/MIN

FLOW RATE

3,4 BAR

MAX

OPERATING PRESSURE



SUZZARABLUE A60 W/ SWIVEL



SUZZARABLUE A60 W/O SWIVEL



PACKAGING

CODE	WEIGHT		PACKAGING		
	KG	LBS	MM	INCH	PCS/BOX
FOO619O2B	2,2	4,8	360X360X280	14,1X14,1X10,8	1
FOO619O3B	2	4,4	360X360X280	14,1X14,1X10,8	1



NOZZLES



FILTRATION



TANK MONITORING



HOSE REEL



ACCESSORIES



MERCHANDISE

INDEX



AIR



ANTIFREEZE



AdBlue®



BIODIESEL



DIESEL



FOOD



GASOLINE



GREASE



KEROSENE



OIL



WATER



WINDSCREEN

CHART

SUZZARABLU A60

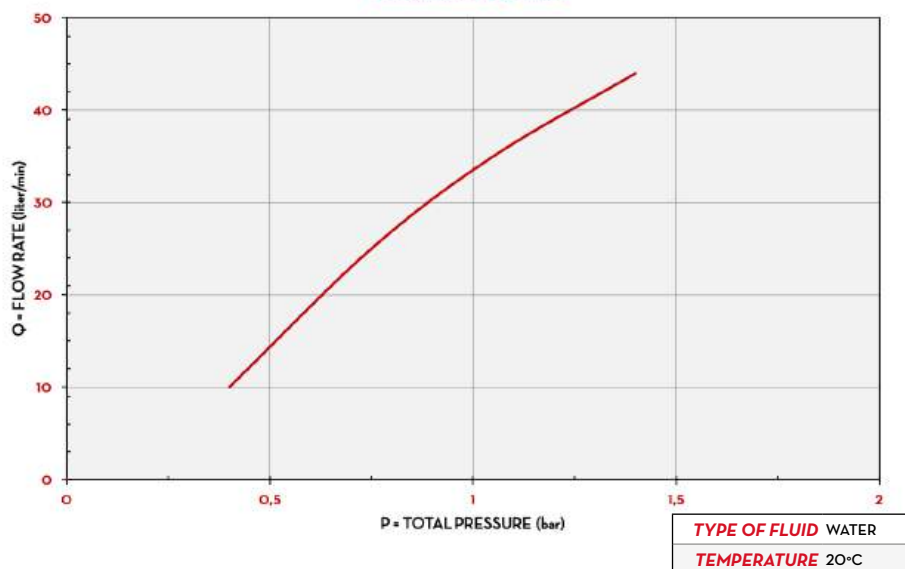

IN THE BOX

- SUZZARABLU A60 NOZZLE
- INSTRUCTION MANUAL

DETAILS



STAINLESS STEEL SPOUT



AUTOMATIC STOP

DIMENSIONS

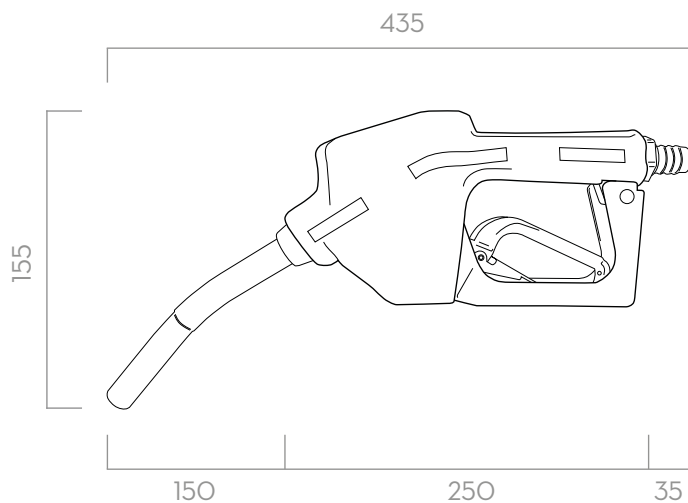

Dimensions expressed in millimeters

MATERIALS

- SPOUT: STAINLESS STEEL
- BODY: STAINLESS STEEL

TECHNICAL DATA

CODE	DESCRIPTION	FLUIDS TYPE	FLOW RATE		PRESSURE BAR	INLET BSP	SWIVEL	SPOUT EXT. Ø
			L/MIN	GPM				
FOO61902B	AUTOMATIC NOZZLE A60 SS W/OUT SWIVEL		40	21,1	3,4	3/4"	NO	19 MM
FOO61903B	AUTOMATIC NOZZLE A60 SS W/ SWIVEL		40	21,1	3,4	3/4"	YES	19 MM



CAR FILLING



FUEL MANAGEMENT SYSTEMS



KITS



PUMPS



METERS



METERED NOZZLES

SUZZARABLUE MANUAL NOZZLE

FEATURES

- READY TO USE
- ERGONOMIC GRAB
- LOW WEIGHT

The PIUSI SUZZARABLUE MANUAL NOZZLE is the basic version of Suzzarablu nozzles designed to dispense AdBlue®. Among the manual devices, it is distinguished by its high efficiency thanks to the low flow resistance, and a very inexpensive operation.

PERFORMANCE

UP TO

80 L/MIN

FLOW RATE

3,4 BAR

MAX

OPERATING PRESSURE



SUZZARABLUE MANUAL NOZZLE



PACKAGING

CODE	WEIGHT		PACKAGING		
	KG	LBS	MM	INCH	PCS/BOX
F14761000	0,2	0,4	800X480X300	31,5X18,9X11,8	1



NOZZLES



FILTRATION



TANK MONITORING



HOSE REEL



ACCESSORIES



MERCHANDISE

INDEX



AIR



ANTIFREEZE



AdBlue®



BIODIESEL



DIESEL



FOOD



GASOLINE



GREASE



KEROSENE



OIL



WATER



WINDSCREEN

CHART

SUZZARABLU MANUAL NOZZLE

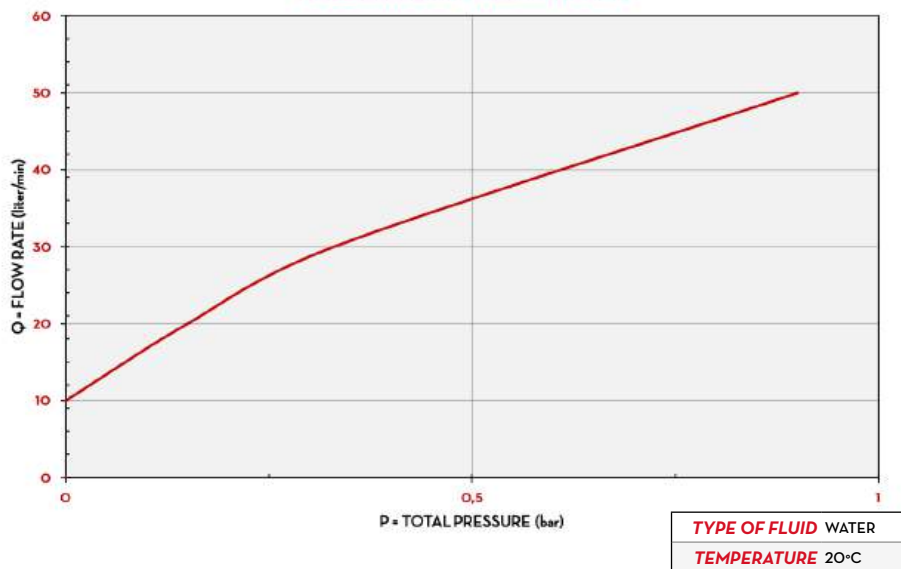

IN THE BOX

- SUZZARABLU MANUAL NOZZLE
- INSTRUCTION MANUAL

DETAILS



STAINLESS STEEL SPOUT



LEVER LOCK

DIMENSIONS

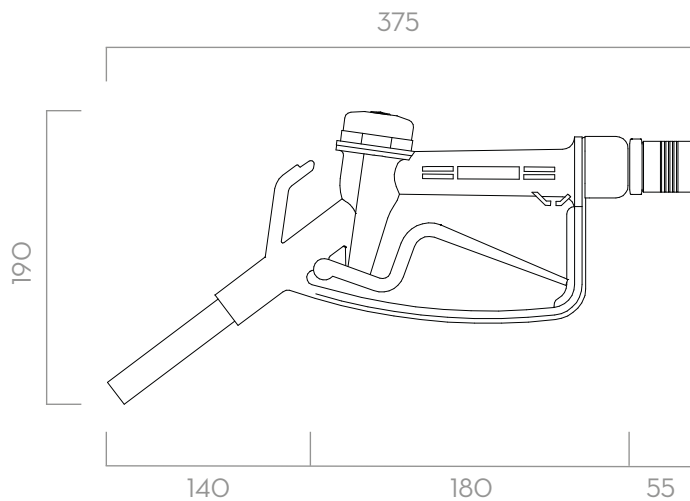

Dimensions expressed in millimeters

MATERIALS

- SPOUT: STAINLESS STEEL
- BODY: TECHNOPYMER



TECHNICAL DATA

CODE	DESCRIPTION	FLUIDS TYPE	FLOW RATE		PRESSURE	INLET	SWIVEL	SPOUT
			L/MIN	GPM				
F14761000	MANUAL NOZZLE		80	10,6	3,4	3/4"	NO	3/4"



NOZZLES ACCESSORIES

AUTOMATIC NOZZLES



SB325_X	CODE	DESCRIPTION	
	F1917400A	KIT FOR SB325_X WITH MISF AND MAG AD	
	R1917200A	KIT SPOUT SB325_X WITH MISFILLING	
	R1917300A	KIT SPOUT SB325_X WITHOUT MISFILLING	
	F18400000	PIUSI MAGNETIC ADAPTOR	
	F15165000	ELAFIX 40 MAGNETIC ADAPTOR	

F1917400A

R1917200A
R1917300A



F15165000

F18400000

SUZZARABLU A60	CODE	DESCRIPTION	
	F16475000	CONNECTOR K24 AUTOMATIC NOZZLE	

F16475000

MANUAL NOZZLE

SUZZARABLU MAN. NOZ.	CODE	DESCRIPTION	
	F15776000	SWIVEL M-F 1IN GAS PLASTIC MANUAL NOZZLE	

F15776000



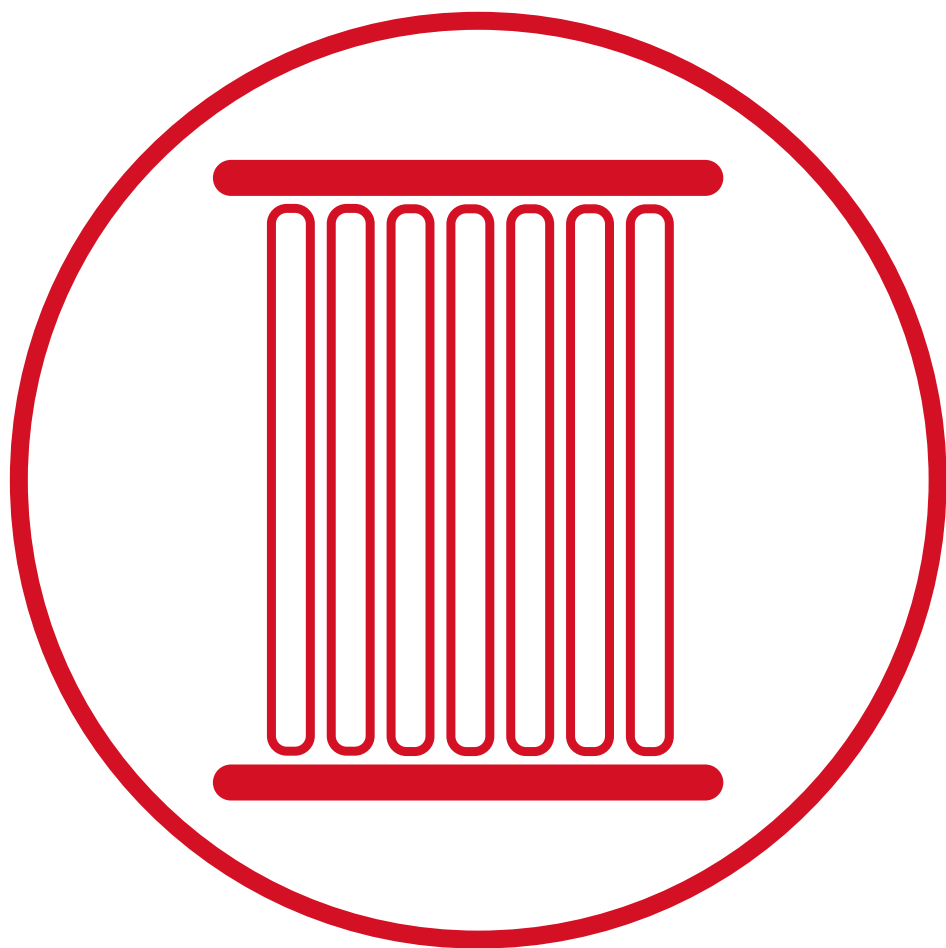

FILTRATION

A large, solid red triangle is positioned in the bottom right corner of the page, pointing towards the top right. The rest of the page is white.



CAR FILLING



FUEL MANAGEMENT SYSTEMS



KITS



PUMPS



METERS



METERED NOZZLES

3D FILTER

FEATURES

- 3-STEP FILTRATION
- HI-RESISTANCE CASE
- REMOVABLE CARTRIDGE
- TRANSPARENT CONTAINER

The PIUSI 3D FILTER is specifically designed to prevent the contamination of AdBlue® during transferring operation. Thanks to the highly efficient (β 200) mechanical filtration, it allows an extended life of the catalyst.

PERFORMANCE

200 μ

FILTERING CAPACITY

4 BAR

MAX

OPERATING PRESSURE



3D FILTER



PACKAGING

CODE	WEIGHT			PACKAGING		
	A MM.	B MM.	C MM.	WEIGHT KG.	DIMENSION MM.	FILTER HEAD PCS/BOX
FO0611D30	136	107	140	0,6	200X120X140	166X144X85
FO0611D40	104	70	104	0,2	166X144X85	-



NOZZLES



FILTRATION



TANK MONITORING



HOSE REEL



ACCESSORIES



MERCHANDISE

INDEX



AIR



ANTIFREEZE



AdBlue®



BIODIESEL



DIESEL



FOOD



GASOLINE



GREASE



KEROSENE



OIL



WATER



WINDSCREEN

FUNCTIONING



Typical condition of the filter after 3650 liters dispensed. We recommend changing the filter cartridge once a year.



High efficiency ($\beta 200$) mechanical filtration of particulate by means of an incremental filter specifically developed for AdBlue®.

IN THE BOX

- 3D FILTER
- INSTRUCTION MANUAL

DETAILS



3D FILTER CARTRIDGE

DIMENSIONS

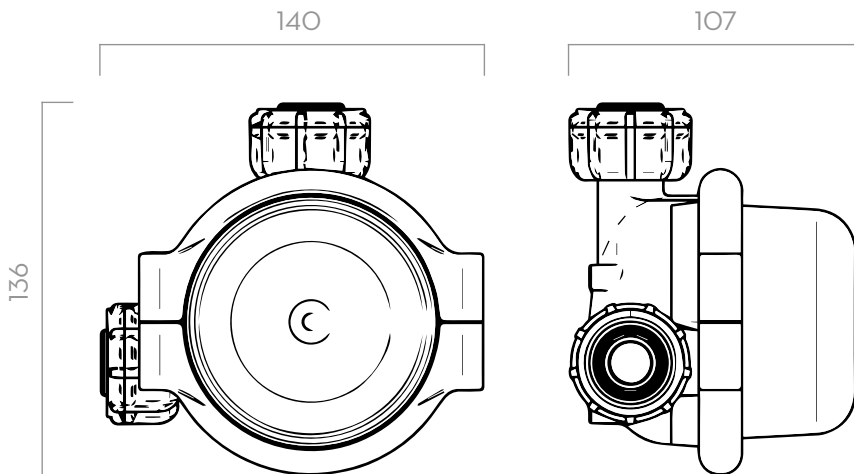

Dimensions expressed in millimeters

MATERIALS

- BODY: TECHNOPOLYMER
- CARTRIDGE: POLYPROPYLENE

TECHNICAL DATA

CODE	DESCRIPTION	FLUIDS TYPE	FLOW RATE		INLET/OUTLET	WATER ABSORBING	EFFICIENCY	MICRO	PRESSION
			L/MIN	GPM					
FOO611D30	CLEAR 3D FILTER + HOUSING		40	10,5	1"	-	200	70	4
FOO611D40	PIUSI CLEAR 3D FILTER/CARTRIDGE		-	-	-	-	-	70	-



TANK MONITORING

A large, solid red triangle is positioned in the bottom right corner of the page, pointing towards the top right. It is a simple, flat color with no text or other details inside it.



CAR FILLING



FUEL MANAGEMENT SYSTEMS



KITS



PUMPS



METERS



METERED NOZZLES

OCIO

FEATURES

- **READY TO USE**
- **BUILT-IN DISPLAY**
- **STAINLESS STEEL PROBE**

OCIO is the PIUSI's tank level indicator specifically designed for AdBlue® thanks to its stainless steel probe. It gives a real time indication of the fluid quantity inside the tank.

PERFORMANCE

UP TO

4MT

HEIGHT

TANK

±1%

FULL SCALE

ACCURACY

UP TO

50 MT

LENGTH

PROBE TUBE



OCIO



10 METERS HOSE



STAINLESS STEEL PROBE

PACKAGING

CODE	WEIGHT		PACKAGING		
	KG	LBS	MM	INCH	PCS/BOX
FO0755140	2,2	4,8	300X410X100	11,8X16,1X3,9	1



NOZZLES



FILTRATION



TANK MONITORING



HOSE REEL



ACCESSORIES



MERCHANDISE

INDEX



AIR



ANTIFREEZE



AdBlue®



BIODIESEL



DIESEL



FOOD



GASOLINE



GREASE



KEROSENE



OIL



WATER



WINDSCREEN

FUNCTIONING

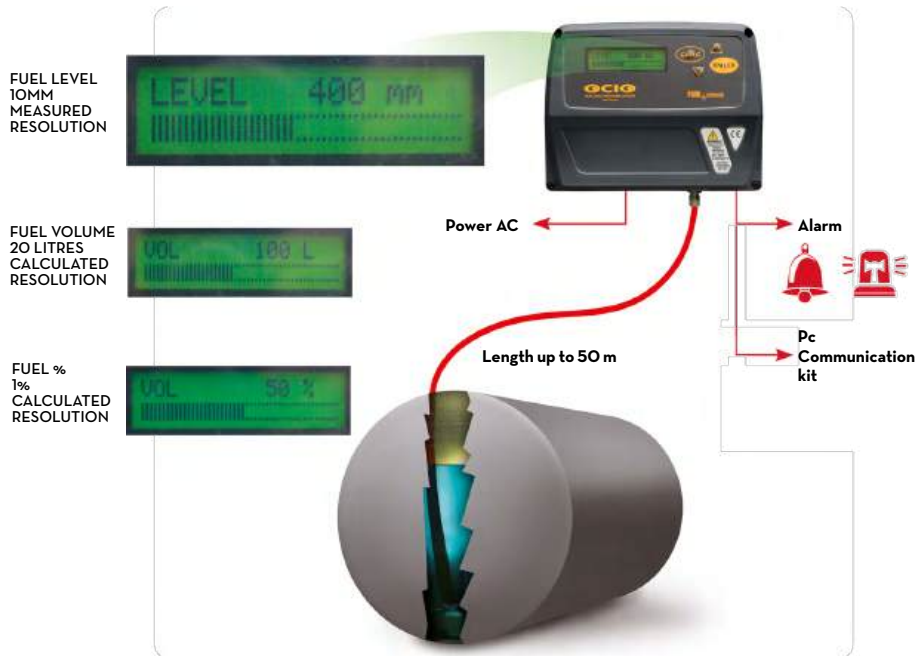

DIMENSIONS

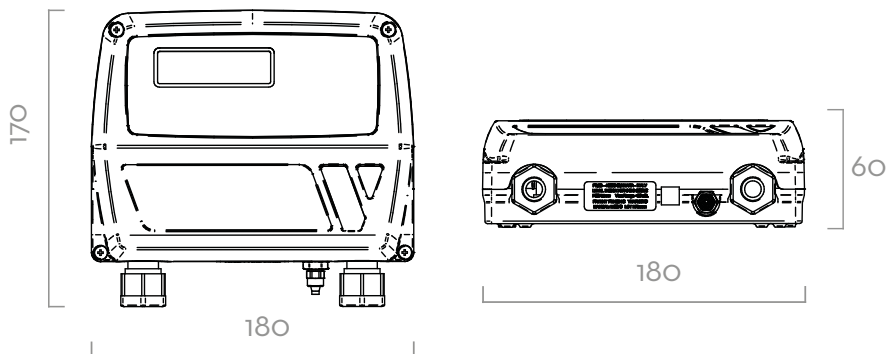

Dimensions expressed in millimeters

IN THE BOX

- OCIO UNIT
- PROBE
- 10 MT TUBE
- INSTRUCTION MANUAL

DETAILS



MATERIALS

- PROBE: STAINLESS STEEL
- TUBE: TECHNOPOLYMER

TECHNICAL DATA

CODE	DESCRIPTION	FLUIDS TYPE	VOLTAGE	
			AC V/Hz	POWER WATT
FO0755140	LEVEL IND.OCIO LV230V 50/60 - ADBLUE	A B D O W W	230/50	20



TANK MONITORING ACCESSORIES

TANK LEVEL INDICATOR

OCIO	CODE	DESCRIPTION
	F1391300A	KIT TUBO OCIO L=50MT
	F15611000	STAINLESS STEEEL PROBE FOR ADBLUE - OCIO



F1391300A F15611000



HOSE REEL

A large, solid red triangle is positioned in the bottom right corner of the page, pointing towards the top left. It occupies approximately the bottom right quarter of the overall image.



CAR FILLING



FUEL MANAGEMENT SYSTEMS



KITS



PUMPS



METERS



METERED NOZZLES

ADBLUE® HOSE REEL

FEATURES

- HEAVY DUTY SPRING
- BUILT-IN HAND PROTECTION
- LONG LASTING

The PIUSI ADBLUE® HOSE REEL for AdBlue®, entirely Made in Italy, features a built-in heavy duty spring. It can be installed on a wall or inside closed cabinets. It is available both with or without hose.

PERFORMANCE

10 BAR

MAX

OPERATING PRESSURE

15 M

HOSE LENGTH



ADBLUE® HOSE REEL



PACKAGING

CODE	WEIGHT		PACKAGING			N. BOXES / EUROPALLET	
	KG	LBS	MM	INCH	PCS/BOX	✕	
WITHOUT HOSE							
FO075006A	14	30,9	550X260X540	21X10X20	1	12	20
WITH HOSE							
FO075007C	17	37,5	550X260X540	21X10X20	1	12	20
FO075011B	24	52,9	550X260X540	21X10X20	1	12	20



NOZZLES



FILTRATION



TANK MONITORING



HOSE REEL



ACCESSORIES



MERCHANDISE

INDEX



AIR



ANTIFREEZE



AdBlue®



BIODIESEL



DIESEL



FOOD



GASOLINE



GREASE



KEROSENE



OIL



WATER



WINDSCREEN

INSTALLATION

Different ways to install PIUSI's hose reels: they can be easily placed wherever you need them without any problem about functionality and safety. PIUSI's products are without a doubt designed to support your work in any condition.

ROOF INSTALLATION

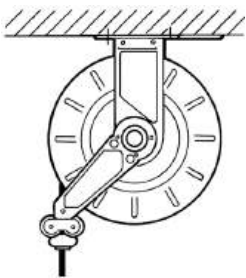

WALL INSTALLATION

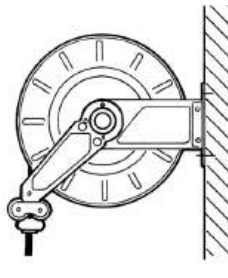

GROUND INSTALLATION

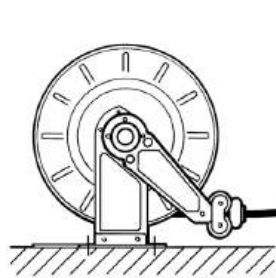

IN THE BOX

- ADBLUE® HOSE REEL
- ACCESSORIES INCLUDED
- FIX SUPPORT PLATE (ON REQUEST)
- ROTATING SUPPORT PLATE (ON REQUEST)
- INSTRUCTION MANUAL

DETAILS



HAND PROTECTION



ACCESSORIES INCLUDED

DIMENSIONS

MODEL	OPEN HOSE REEL BIG	OPEN HOSE REEL SMALL
A	495	475
B	460	460
C	152	102
D	200	150
E	246	196
F	150	150
G	200	150
H	12	12

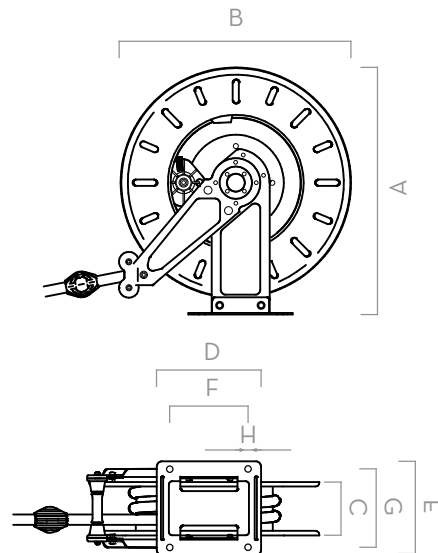

Dimensions expressed in millimeters

MATERIALS

- BODY: CAST IRON
- HUB: POLYPROPYLENE
- TUBE: RUBBER

TECHNICAL DATA



CODE	DESCRIPTION	FLUIDS TYPE	HOSE*	MAX OPERATING PRESSURE (BAR)	PRESSURE DROP TYPE	INLET	OUTLET	HOSE MAX LENGTH BOUND* (METERS)	HOSE LENGTH
			BPS			WITH HOSETAIL BSP	BSP		METER
WITHOUT HOSE									
FO075006A	ADBLUE HOSE REEL " BSP W/O HOSE SMALL		3/4"	10	0,1 @ 35 L/MIN	3/4"	3/4"	9,5	-
WITH HOSE									
FO075007C	ADBLUE HOSE REEL " BSP W/HOSE 8MT		3/4"	10	0,4 @ 35 L/MIN	3/4"	3/4"	-	8
FO075011B	ADBLUE HOSE REEL " BSP W/HOSE 15MT		3/4"	10	0,6 @ 35 L/MIN	3/4"	3/4"	-	15



HOSE REELS ACCESSORIES

OPEN HOSE REEL

ADBLUE® HOSE REEL	CODE	DESCRIPTION
	F1731600A	SMALL HOSE REEL FIXED BASE
	F1731700A	SMALL HOSE REEL ROTATING SUPPORT
	F17275000	KIT PLATE HOSE REEL TANK IBC
	F1629800A	BIG HOSE REEL FIXED BASE
	F1627900A	BIG HOSE REEL ROTATING SUPPORT
	F1818700A	CLAMP D.27-29 HOSEREEL UREA/SMALL



F1731600A
F1629800A

F1731700A
F1627900A

F17275000



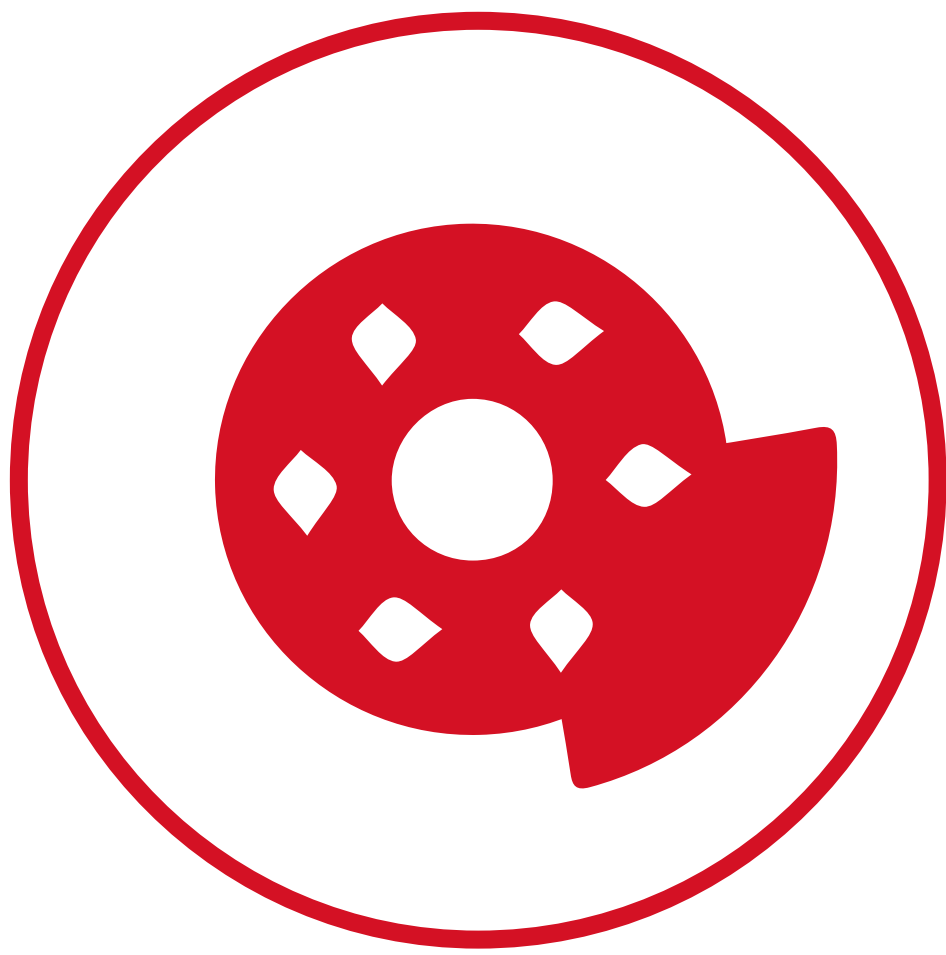

ACCESSORIES

A large, solid red triangle is positioned in the bottom right corner of the page, pointing towards the top right.



CAR FILLING



FUEL MANAGEMENT SYSTEMS



KITS



PUMPS



METERS



METERED NOZZLES

CONNECTIONS & CONNECTORS

FEATURES

- SEVERAL SHAPES
- PERFECTLY FIT EVERY EQUIPMENT
- COMPLIANT TO ISO22241 NORM

The PIUSI range of CONNECTIONS & CONNECTORS for AdBlue® is manufactured with materials compliant to the ISO22241 norm: AF2 or SEC that perfectly fits every application context, KIT BOTTOM CONNECTION, SUCTION CONNECTION and GRAVITY KIT for non-electric fluid transfer.

CONNECTIONS

TECHNICAL DATA

CODE	DESCRIPTION	FLUID	LENGTH	INLET / OUTLET		HOSE	PIECES/BOX
			METERS (M)	A	B	Ø (MM)	

GRAVITY KIT

F1551700A	SUZZARA BLUE GRAVITY KIT		3 M	F 2" BSP	NOZZLE	-	1
-----------	--------------------------	--	-----	----------	--------	---	---

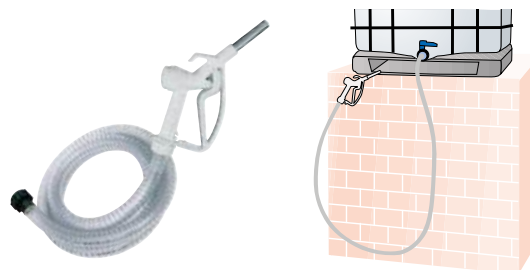

SUZZARABLUE GRAVITY KIT

KIT BOTTOM CONNECTION

F15515010	KIT BOTTOM CONNECTION W/FOOT VALVE 0.3MT		0,3 M	F 2" BSP	1" X D.25	-	1
F15515000	KIT BOTTOM CONNECTION W/FOOT VALVE 1.5MT		1,5 M	F 2" BSP	1" X D.25	-	1



F15515010



F15515000

SUCTION CONNECTION

F15606020	SUCTION DIP TUBE SUZZARABLUE 2" BSP		-	D.20 MM	2" BSP	-	1
F15606000	SUCTION DIP TUBE SUZZARABLUE 56X4		-	D.20 MM	56X4 BUTT	-	1
F15606010	SUCTION DIP TUBE SUZZARABLUE 2" BUTT		-	D.20 MM	2" BUTT	-	1

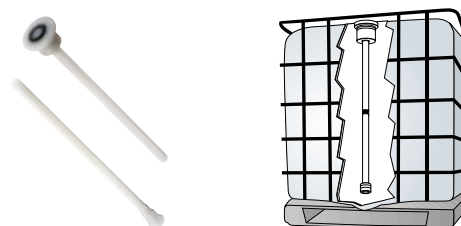

SUCTION CONNECTION



NOZZLES



FILTRATION



TANK MONITORING



HOSE REEL



ACCESSORIES



MERCHANDISE

INDEX



AIR



ANTIFREEZE



AdBlue®



BIODIESEL



DIESEL



FOOD



GASOLINE



GREASE



KEROSENE



OIL



WATER



WINDSCREEN

CONNECTORS

TECHNICAL DATA

CODE	DESCRIPTION	FLUID	LENGTH	INLET / OUTLET		HOSE	PIECES/BOX
			METERS (M)	A	B	Ø (MM)	

AF2

F20189000	AF2 56X4 BUTTRESS / M 1"		-	56X4 BUTT	M 1"	-	1
F20190000	AF2 2" BUTTRESS / M 1"		-	2" BUTT	M 1"	-	1
F20257000	AF2 2" BSP / M 1"		-	2" BSP	M 1"	-	1
F20258000	AF2 2" 70X6 / M 1"		-	2" 70X6	M 1"	-	1



AF2

SEC

F15339000	SEC CONNECTOR / M 3/4"		-	SEC	M 3/4"	-	1
F15452000	SEC CONNECTOR + HOSE TAIL 90° M 3/4"		-	SEC	M 3/4"	-	1



SEC



CAR FILLING



FUEL MANAGEMENT SYSTEMS



KITS



PUMPS



METERS



METERED NOZZLES

COUPLING & FITTINGS

FEATURES

- **STURDY DESIGN**
- **PERFECTLY FIT EVERY EQUIPMENT**
- **COMPLIANT TO ISO22241 NORM**

Safe, sturdy and reliable: the PIUSI range of COUPLING & FITTINGS is expressly engineered for AdBlue® (compliant to ISO22241 norm). Several shapes and dimensions make this range suitable for every use.

COUPLING & FITTINGS

TECHNICAL DATA

CODE	DESCRIPTION	FLUID	LENGTH	INLET / OUTLET		HOSE	PIECES/BOX
			METERS (M)	A	B	Ø (MM)	

HOSETAILS

F15522000	HOSETAIL M 1" X D.20 PLASTIC		-	M 1" BSP	-	20	1
F16435000	HOSETAIL F 1" X D.20 WITH NUT		-	F 1" BSP	-	20	1



F15522000



F16435000

ELBOWS

F15484000	HOSETAIL 90° D.19 F 1" BSP FOR K24 METER		-	F 1" BSP	-	19	1
F15450000	HOSETAIL 90° D.19 F 3/4" BSP		-	F 3/4" BSP	-	19	1
F16433000	PIPE FITTING 90° 2/F 1" BSP RING		-	F 1" BSP	-	-	1
F15485000	HOSETAIL 90° D.19 1" BSP W/NUT W/NIPPLE		-	1" BSP	-	19	1



F15484000



F15450000



F16433000



F15485000

FITTINGS

F16434000	STRAIGHT CONNECTION WITH 2 NUTS F 1" BSP		-	F 1" BSP	F 1" BSP	-	1
-----------	--	--	---	----------	----------	---	---



F16434000



NOZZLES



FILTRATION



TANK MONITORING



HOSE REEL



ACCESSORIES



MERCHANDISE

INDEX



AIR



ANTIFREEZE



AdBlue®



BIODIESEL



DIESEL



FOOD



GASOLINE



GREASE



KEROSENE



OIL



WATER



WINDSCREEN

COUPLING&FITTINGS

TECHNICAL DATA

CODE	DESCRIPTION	FLUID	LENGTH	INLET / OUTLET		HOSE	PIECES/BOX
			METERS (M)	A	B	Ø (MM)	

SLEEVE

F16073000	SLEEVE F 1" BSP / F 1" BSP (20 PCS) SS		-	F 1" BSP	F 1" BSP	-	20
F16458000	SLEEVE F 1" NPT / F 1" BSP (20 PCS) SS		-	F 1" NPT	F 1" BSP	-	20



F16073000
F16074000
F16458000

COUPLINGS

F15176000	NIPPLE M 1" BSP / M 1" BSP PLASTIC		-	M 1" BSP	M 1" BSP	-	1
-----------	------------------------------------	--	---	----------	----------	---	---



F15176000

SWIVEL UNION

F15776000	SWIVEL UNION M 1" BSP / F 1" BSP		-	M 1" BSP	F 1" BSP	-	1
-----------	----------------------------------	--	---	----------	----------	---	---



F15776000



CAR FILLING



FUEL MANAGEMENT SYSTEMS



KITS



PUMPS



METERS



METERED NOZZLES

HOSE&SWIVEL

FEATURES

- SEVERAL LENGTH
- WIDE ARRAY OF SHAPES
- COMPLIANT TO ISO22241 NORM

PIUSI has designed a complete range of HOSES&SWIVEL for AdBlue® that meets the most common usages requirements: rigid or flexible hoses to be used inside or outside the tanks, crimped, spiral, submersible and non submersible hoses; all compliant to ISO22241 norm.

HOSE&SWIVEL

TECHNICAL DATA

CODE	DESCRIPTION	FLUID	LENGTH	INLET / OUTLET		HOSE	PIECES/BOX
			METERS (M)	A	B	Ø (MM)	

CLAMP

F1380000	STAINLESS STEEL CLAMPS (10PCS)	-	-	-	-	-	10
----------	--------------------------------	---	---	---	---	---	----

**CLAMP**

DELIVERY HOSES

F14250000	DELIVERY EPDM HOSE .7" 4MT		4 M	-	-	3/4" - 19	1
F14125020	DELIVERY EPDM HOSE .7" 6MT		6 M	-	-	3/4" - 19	1
F14125030	DELIVERY EPDM HOSE .7" 8MT		8 M	-	-	3/4" - 19	1
F14125040	DELIVERY EPDM HOSE .7" 10MT		10 M	-	-	3/4" - 19	1
F1412505B	DELIVERY EPDM HOSE .7" 50MT		50 M	-	-	3/4" - 19	1

**DELIVERY HOSES**

DELIVERY CRIMPED HOSES

F1907200A	DELIVERY EPDM CRIMPED HOSE F. 3/4" BSP 6MT		6 M	F 3/4" BSP	-	3/4" - 19	1
-----------	--	--	-----	------------	---	-----------	---

**DELIVERY CRIMPED HOSES**

SUBMERSIBLE SUCTION SPIRAL HOSES

F1412400B	SUCTION SPIRAL SS EPDM HOSE .7" 15MT		15 M	3/4"	-	3/4" - 19	1
F15883000	KIT SUCTION SPIRAL EPDM HOSE 1.1MT W/SEC		1,1 M	SEC	-	3/4" - 19	1

**F1412400B****F15883000**



NOZZLES



FILTRATION



TANK MONITORING



HOSE REEL



ACCESSORIES



MERCHANDISE

INDEX



AIR



ANTIFREEZE



AdBlue®



BIODIESEL



DIESEL



FOOD



GASOLINE



GREASE



KEROSENE



OIL



WATER



WINDSCREEN

HOSE&SWIVEL

TECHNICAL DATA

CODE	DESCRIPTION	FLUID	LENGTH	INLET / OUTLET		HOSE	PIECES/BOX
			METERS (M)	A	B	Ø (MM)	

NON SUBMERSIBLE SUCTION SPIRAL HOSES

F14146000	KIT SUCTION HOSE EPDM 1,5MT W/FOOT VALVE		1,5 M	FOOT VALVE	-	3/4" - 19	1
F1424900A	SUCTION SPIRAL EPDM HOSE .7" 1.5MT		1,5 M	-	-	3/4" - 19	1
F19014000	SUCTION SPIRAL EPDM HOSE .7" 30MT		30 M	-	-	3/4" - 19	1
F19286000	SUCTION EPDM HOSE .7" 1.5MT CRIMP 1 SIDE		1,5 M	3/4"	-	3/4" - 19	1



F14146000



F1424900A



F19014000

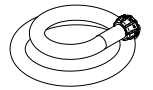

F19286000

HOSE PROTECTION

F1649700A	RUBBER PROTECTOR FOR HOSE .7"		-	3/4"	-	-	1
-----------	-------------------------------	--	---	------	---	---	---



F1649700A

SWIVEL

F14132000	SWIVEL M .7" BSP X D.19 STAINLESS STEEL		-	M 3/4" BSP	-	19 MM	1
F15437000	SWIVEL M .7" BSP X D.25 STAINLESS STEEL		-	M 3/4" BSP	-	25 MM	1

F14132000
F15437000



MERCHANDISE





CAR FILLING



FUEL MANAGEMENT SYSTEMS



KITS



PUMPS



METERS



METERED NOZZLES

MERCHANDISE



PACKAGING

CODE	DESCRIPTION	WEIGHT		PACKAGING			
		KG	LBS	MM	INCH	PCS/PALLET	PCS/BOX
T-SHIRT WHITE							
PBG000026	PIUSI T-SHIRT WHITE BOX 10 PCS - L	1	-	35X26X18	-	-	10
PBG000027	PIUSI T-SHIRT WHITE BOX 10 PCS - XL	1	-	35X26X18	-	-	10
PBG000029	PIUSI T-SHIRT WHITE BOX 10 PCS - M	1	-	35X26X18	-	-	10
UMBRELLA							
PBG000030	PIUSI UMBRELLA - BOX 10 PCS	5,5	-	35X26X18	-	-	10
BAG							
PBG000035	PIUSI BAG 2018 - BOX 150 PCS	18,5	-	-	-	-	150
KEYRING							
PBG000041	PIUSI KEYRING - BOX 100 PCS	-	-	-	-	-	100



NOZZLES



FILTRATION



TANK MONITORING



HOSE REEL



ACCESSORIES



MERCHANDISE

INDEX



PACKAGING

CODE	DESCRIPTION	WEIGHT		PACKAGING			
		KG	LBS	MM	INCH	PCS/PALLET	PCS/BOX
METALLIC FLOOR STAND							
PBA000013	PIUSI METALLIC FLOOR STAND	76	-	120X100 (PALLET)	-	1	-
PIUSI FLAG							
PBA000030	DROP DISPLAY PIUSI - ADV	8	-				1

PIUSI FLUIDS' INFORMATION

ABOUT ADBLUE®

PIUSI SpA has been a leading manufacturer of fuel and lubricant transfer equipment since 1953, with a particular focus on the supply of pumps, flow meters, compressors and measuring instruments.

Diesel Exhaust Fluid (DEF): New Directives aimed at reducing the emission of pollutants into the atmosphere are complied with by **installing a catalyser** on the truck (SCR), which requires the use of a **special liquid blend of water and urea known as AdBlue®**, Arla or AUS 32 depending on reference market.

Every truck has to be equipped with an additional tank to store this special liquid. On the basis of meticulous analyses of the issues relating to urea transfer, **PIUSI has developed a reliable range of products made with materials that are compatible** with this fluid.

AdBlue® is a non-toxic urea solution used for chemically reducing nitrogen oxide (NOx) levels in diesel engine exhaust gases.

With effect from **1 January 2005**, all new vehicles sold in Europe must comply with the **Euro 4 standard**, which significantly limits polluting emissions.

AdBlue® enables latest-generation heavy vehicles to meet the envisaged limits, without compromising the performance or efficiency of their engines in any way.

With over 40,000 pumps and transfer equipment for AdBlue®/DEF installed throughout Europe, PIUSI is helping companies and government bodies to reduce NOx emissions as required by European legislation.

PIUSI offers a comprehensive range of transfer equipment and dispensers for AdBlue®, including pumps, flow meters, nozzles and all the necessary accessories for Urea transfer units.

The units can be easily applied to and removed from IBC tanks and drums.

The company also offers a series of **solutions for monitoring fluid levels in tanks and the quantities dispensed** by users.



TYPE OF FLUIDS

AIR

A

ANTIFREEZE

A

AdBlue® (UREA)

Ad

BIODIESEL

B

DIESEL

D

FOOD

F

GASOLINE

G

GREASE

G^R

KEROSENE

K

OIL

O

WATER

W

WINDSCREEN

W_S

The intellectual property of this catalogue is assigned to all countries. Translation, reproduction, electronic storage and full or partial adaption by any means (including microfilms and photocopies) of its contents, without prior written authorisation from PIUSI S.p.a., entails a violation of PIUSI S.P.A's copyrights and constitutes an act of unfair competition. The products shown in the images of this catalogue are protected according to the regulation in force regarding industrial property. The information contained in this catalogue is as accurate as possible and complies, as far as possible, with existing regulations at the time of its publication. We therefore reserve the right to make subsequent modifications in line with modifications to regulations and/ or in relation to any production requirements that are deemed necessary for safety reasons. The technical specifications indicated in this catalogue cancel out and replace those already present in the previous general catalogue and in the product catalogues. The updates and product data sheets are available in PDF format on our website:

www.piusi.com

Since 1953, piusi has been employing italian engineering skills at the service of its customers, with professionalism and integrity in order to build stable and lasting relationships.

Our mission is to provide simple, intelligent and professional solutions for the transfer, dispense and measurement of lubricants, fuels and liquids, with the highest consideration for human and environmental health.



PIUSI S.p.A.

Headquarters
46029 Suzzara (Mantova) Italy
tel.+39 0376 534561
fax.+39 0376 536393
e-mail: piusi@piusi.com
www.piusi.com

PIUSI USA, Inc.

3901 Anglers Avenue Fort Lauderdale, FL 33312
tel.: 954 584 1552
fax.: 954 584 1554
e-mail: piusiusa@piusi.com
www.piusi.com

